



A Dana Brand 

The text 'A Dana Brand' is in a black, italicized serif font. To its right is the Dana logo, which consists of a blue diamond shape with the word 'DANA' in white, bold, sans-serif capital letters inside.

Driveshafts for Industrial Applications





Table of Contents

- 1 Dana: Driveshaft engineering experts**
- 4 Survey of GWB™ driveshaft series with design features and preferred applications**
- 8 Special designs of GWB driveshafts and additional equipment**
- 10 Notations for reviewing data sheets**

Data sheets

- 12 Series 687/688
- 16 Series 587
- 18 Series 390
- 20 Series 392/393
- 22 Series 492
- 24 Series 498
- 26 Series 587/190 Super short designs
- 28 Series 330 Quick release couplings
- 29 Series 230 Quick release couplings
- 30 Journal cross assemblies
- 31 Flange connection with serration
- 32 Face key connection
series 687/688/587/390
- 33 Standard companion flanges
- 34 Design features Series 687/688/587 and series 390/392/393**
- 36 General theoretical instructions**
- 38 Technical instructions for application**
- 48 Selection of GWB driveshafts**
- 51 Additional information and ordering instructions**
- 52 After-sales service**

Dana: Driveshaft engineering experts For more than 100 years, Dana's expertise and worldwide network of manufacturing partnerships have sustained its ability to supply economically efficient, high-performance products to original equipment manufacturers (OEMs) in changing market environments.



With a focus on technical innovation, quality performance, reliability, and flexibility, Dana engineers continue to provide customers with the same quality and support they've come to expect.

Since 1946, Dana's **GWB™** driveshafts have been known for global innovation and quality performance. **GWB** heavy driveshafts

were the first to be developed specifically for diesel locomotives. In the 1950s, **GWB** driveshafts were the largest available at that time, and were followed several decades later by the first maintenance-free driveshaft. Based on a long-standing commitment to continual innovation and customer satisfaction, **GWB** driveshafts have been recognized as a

market leader through-out the world.

GWB driveshafts include a wide range of products for multiple applications, covering a torque range from 2.400 to 16.300.000 Nm.

GWB®





Today, there are basically two types of driveshafts that have evolved into a worldwide technology standard. Their main difference lies in the design of the bearing eye.

Closed bearing eye: This is a design used mainly in the commercial vehicles sector and for general mechanical engineering applications (series 687/688 and 587).

Split bearing eye: Developed for heavy and super-heavy duty applications, this design (series 390/392/393 and 492/498), provides compact dimensions in conjunction with a maximum

torque transmission capability and greatly improved service life, apart from facilitating maintenance and assembly operations.

2.400 - 16.300.000 Nm

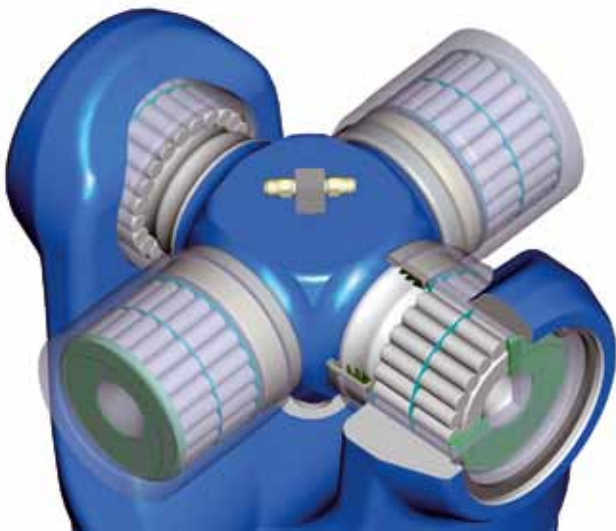

▲
Closed bearing eye

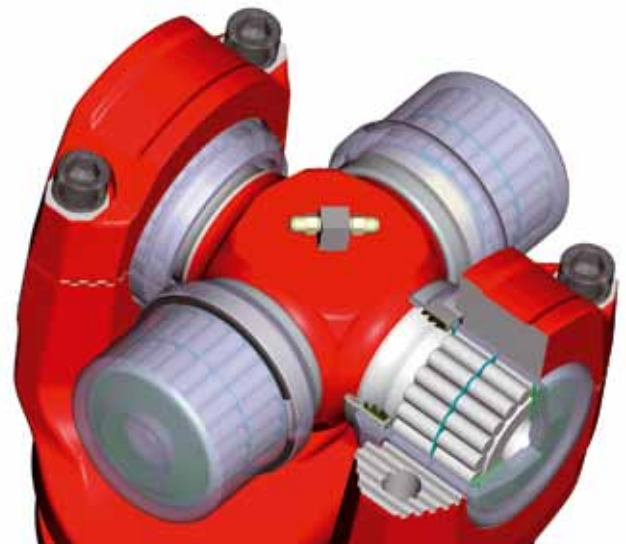

▲
Split bearing eye



Survey of **GWB™** driveshaft series

Series

687/688

Torque range T_{cs}
from 2,4 to 35 kNm

Flange diameter
from 100 to 225 mm

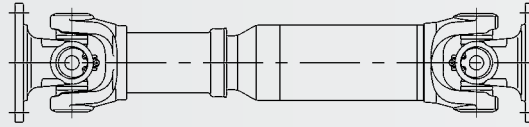

587

Torque range T_{cs}
from 43 to 57 kNm

Flange diameter
from 225 to 285 mm

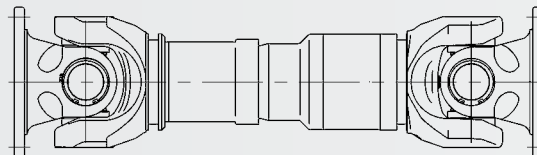

390

Maximum bearing life

Torque range T_{cs}
from 60 to 255 kNm

Flange diameter
from 285 to 435 mm

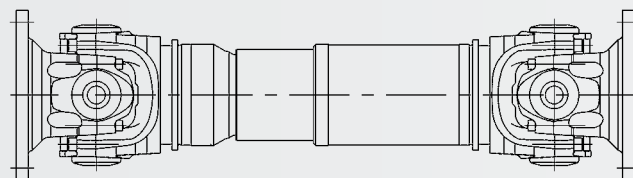

Survey of **GWB™** driveshaft series

Design features

- Closed bearing eyes
- Compact design
- Low maintenance
- Plastic-coated splines
- Operating angle up to 25°, partly up to 44°

Preferred applications

- Railway vehicles
- Rolling mill plants
- Marine drives
- General machinery construction plants

Technical data (refer to data sheets)

- Closed bearing eyes
- Compact design
- Low maintenance
- Splines coated with lubricating varnish (587.50 – plastic-coated)
- Operating angle up to 24°

- Railway vehicles
- Rolling mill plants
- Marine drives
- General machinery construction plants

Technical data (refer to data sheets)

- Maximum bearing life in confined spaces
- Split bearing eyes with toothed bearing cap
- Compact design
- Optimized roller bearing
- Length compensation coated with lubricating varnish
- Operating angle up to 15°

- Railway vehicles
- Marine drives
- Crane systems
- Paper machines
- General machinery construction plants

Technical data (refer to data sheets)



Survey of **GWB™** driveshaft series

Series

392/393

**High torque capacity/
optimized bearing life**

Torque range T_{cs}
from 70 to 1.150 kNm

Flange diameter
from 225 to 550 mm

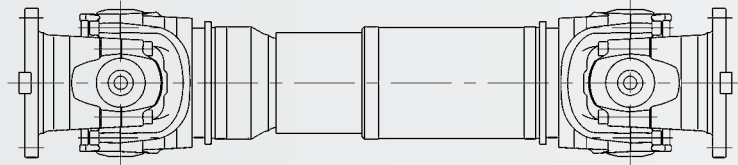

492

Maximum torque capacity

Torque range T_{cs}
from 210 to 1.300 kNm

Flange diameter
from 285 to 550 mm

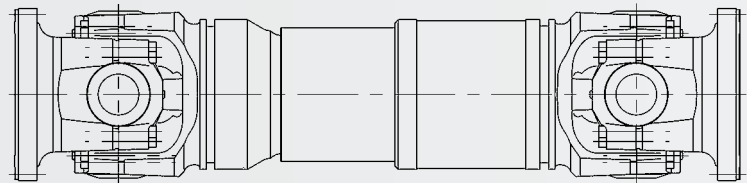

498

**Larger sizes available
on request**

Torque range T_{cs}
from 1.880 to 15.000 kNm

Flange diameter
from 600 to 1.200 mm

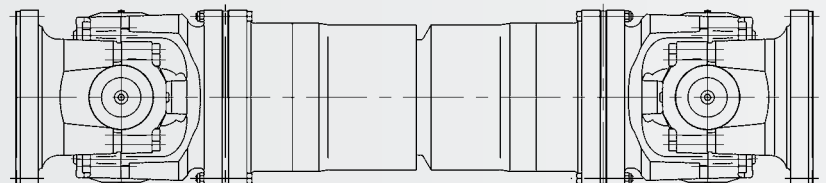

Survey of **GWB™** driveshaft series

Design features

- High torque capacity despite small connecting dimensions
- Split bearing eyes with toothed bearing cap
- Compact design
- Journal cross with low notch factor
- Length compensation coated with lubricating varnish
- Operating angle 10° up to 15°
- Series 393 with optimized bearing life

Preferred applications

- Rolling mill plants
- Calender drives
- Heavy-loaded plants of general machinery construction

Technical data (refer to data sheets)

- Increased torque capacity in comparison to 393
- Split bearing eyes with toothed bearing cap
- Standard Hirth-serrated flange
- Journal cross with low notch factor
- Length compensation coated with lubricant varnish
- Operating angle 7° up to 15°

- Rolling mill plants
- Calender drives
- Extremely high loaded plants of general machinery construction

Technical data (refer to data sheets)

- Three operating angle versions for maximum torque or maximum bearing life capacity
- Split bearing eyes with toothed bearing cap
- Standard Hirth-serrated flange
- Operating angle up to 15°

- Main rolling mill drive units
- Heavy machinery construction plants

Technical data (refer to data sheets)



Special designs of **GWB™** driveshafts and additional equipment

Series

587/190

Super short designs

Torque range T_{Cs}
from 23 to 94 kNm

Flange diameter
from 275 to 405 mm

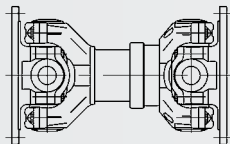

392/393

Tunnel joint shafts

Torque range T_{Cs}
from 57 to 1.053 kNm

Flange diameter
from 225/315 to
550/710 mm

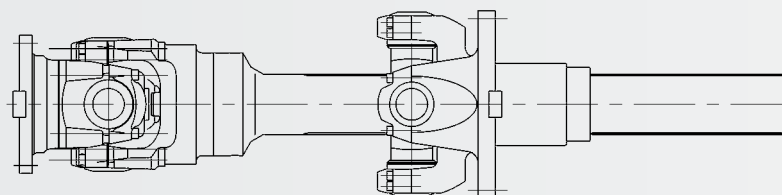

Intermediate shafts

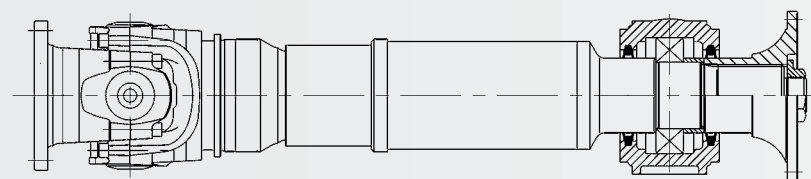

Special designs of **GWB™** driveshafts and additional equipment

Design features

- Closed bearing eyes (series 587)
- Split bearing eyes (series 190)
- Joints and length compensation are regreasable
- Operating angle up to 5°

Preferred applications

- Railway vehicles
- Rolling mill plants
- Marine drives
- Calender drives
- Paper machines
- General machinery construction plants

Technical data (refer to data sheets)

- Shorter designs with large length compensation
 - Length compensation through the joint
 - High torque capacity with small connection dimensions
 - Split bearing eyes with toothed bearing cap
 - Bearings with labyrinth seals
 - Operating angle up to 10°/7,5°
- Rolling mill plants

- With or without length compensation
 - Integrated bearing location
- Pump drives

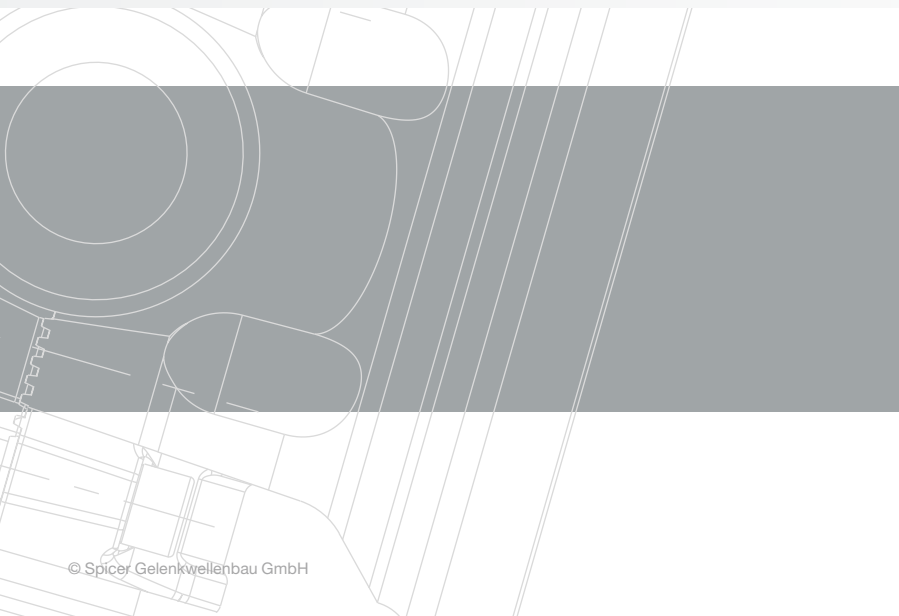

Notations for reviewing data sheets

Standard designs

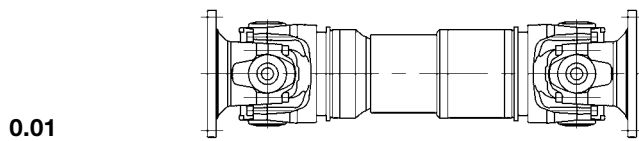

Driveshaft with length compensation, tubular design

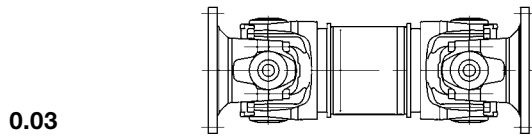

Driveshaft without length compensation, tubular design

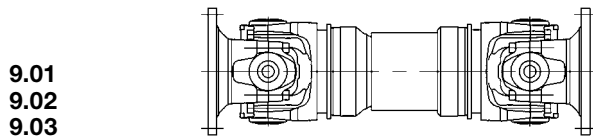

Driveshaft with length compensation, short design

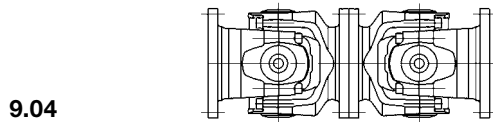

Driveshaft without length compensation, double flange shaft design

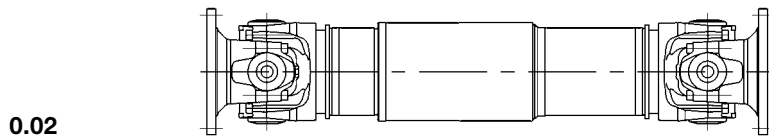

Driveshaft with large length compensation, tubular design

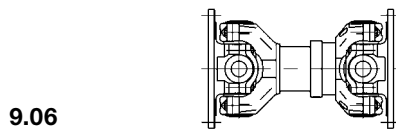

Driveshaft with length compensation, super short design





Intermediate shafts*

(available with intermediate bearing on request)

Intermediate shaft with length compensation

Intermediate shaft without length compensation

Midship shaft

* Data sheet and/or drawing available on request.

0.04

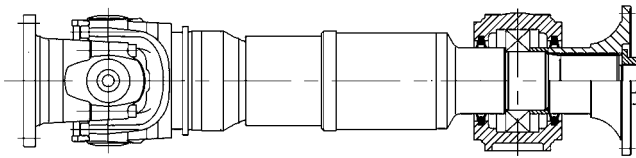

0.04

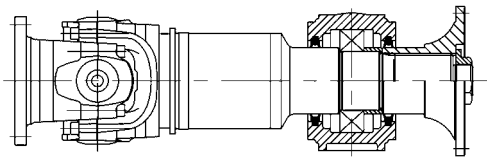

0.01

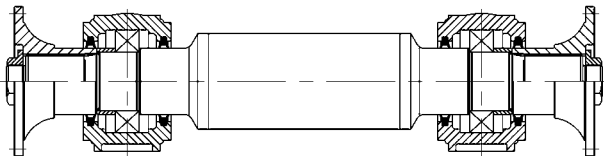

Data sheet series 687/688

0.02 with length compensation, tubular design
 0.03 without length compensation, tubular design
 9.01 with length compensation, short design

9.03 with length compensation, short design
 9.04 without length compensation, double flange shaft design

Design

0.02

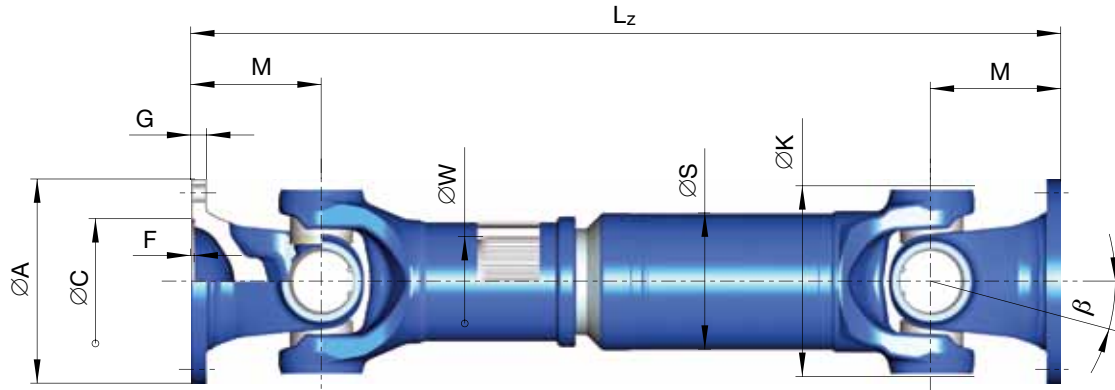

Shaft size		687/688.15	687/688.20	687/688.25	687/688.30		687/688.35		687/688.40			
T _{CS}	kNm	2,4	3,5	5	6,5		10		14			
T _{DW}	kNm	0,7	1,0	1,6	1,9		2,9		4,4			
L _c	-	1,79 x 10 ⁻⁴	5,39 x 10 ⁻⁴	1,79 x 10 ⁻³	2,59 x 10 ⁻³		0,0128		0,0422			
β	°	25	25	25	25		25		25	44	25	44
A	mm	100	120	120	120	150	150	180	150	150	180	180
K	mm	90	98	113	127	127	144	144	160	160	160	160
B ± 0,1 mm	mm	84	101,5	101,5	101,5	130	130	155,5	130	130	155,5	155,5
C H7	mm	57	75	75	75	90	90	110	90	90	110	110
F ¹⁾	mm	2,5	2,5	2,5	2,5	3	3	3	3	3	3	3
G	mm	7	8	8	8	10	10	12	10	10	12	12
H + 0,2 mm	mm	8,25	10,25	10,25	10,25	12,25	12,1	14,1	12,1	12,1	14,1	14,1
I ²⁾	-	6	8	8	8	8	8	8	8	8	8	8
M	mm	48	54	70	72	78	95	90	102	102	102	102
S	mm	63,5 x 2,4	76,2 x 2,4	89 x 2,4	90 x 3	90 x 3	100 x 3	100 x 3	120 x 3	100 x 4,5	120 x 3	100 x 4,5
W DIN 5480	mm	36 x 1,5	40 x 1,5	45 x 1,5	48 x 1,5	48 x 1,5	54 x 1,5	54 x 1,5	62 x 1,75			

T_{CS} = Functional limit torque*
 If the permissible functional limit torque T_{CS} is to be fully utilized, the flange connection must be reinforced.

T_{DW} = Reversing fatigue torque*
L_c = Bearing capacity factor*
 * See specifications of driveshafts.
 β = Maximum deflection angle per joint

Tubular shafts with welded-on balancing plates have lower fatigue torques T_{DW}
 1) Effective spigot depth
 2) Number of flange holes

Data sheet series 687/688

Design

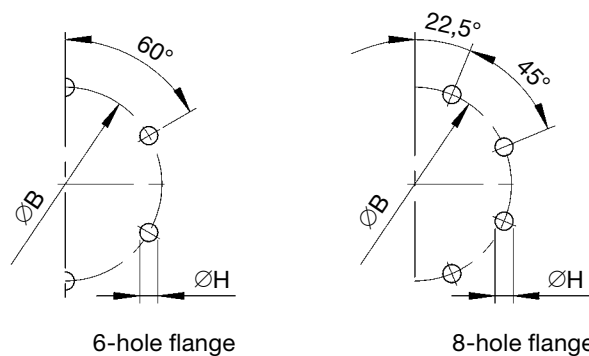
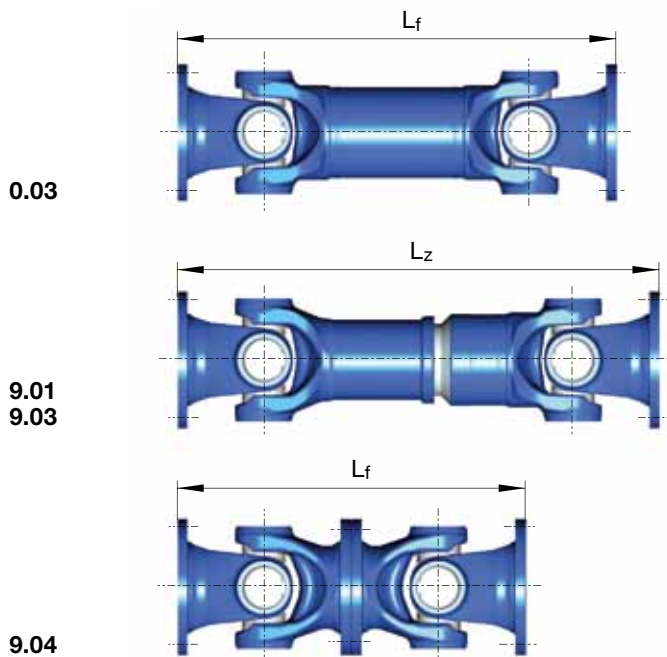

**NOTE: Hole patterns are not optional.
Each driveshaft size has a specific hole pattern.**

Design	Shaft size	687/688.15		687/688.20		687/688.25		687/688.30		687/688.35		687/688.40		
0.02	L _{z min}	mm	346	379	458	492	504	582	572	586	693	586	693	
	L _a	mm	60	70	100	110	110	110	110	110	110	180	110	180
	G	kg	5,7	8,4	12,0	13	14,2	24,0	25,6	28,7	30,3	29,4	30,9	
	G _R	kg	3,62	4,37	5,13	6,44	6,44	7,18	7,18	8,66	10,6	8,66	10,6	
	J _m	kgm ²	0,0043	0,0089	0,0144	0,0245	0,0245	0,043	-	0,0676	0,0706	0,0776	0,0806	
	J _{mR}	kgm ²	0,0034	0,0059	0,0096	0,0122	0,0122	0,0169	0,0169	0,0296	0,0242	0,0296	0,0242	
	C	Nm/rad.	0,26 x 10 ⁵	0,42 x 10 ⁵	0,71 x 10 ⁵	0,78 x 10 ⁵	0,78 x 10 ⁵	1,18 x 10 ⁵	-	2,17 x 10 ⁵	1,61 x 10 ⁵	2,17 x 10 ⁵	1,61 x 10 ⁵	
	C _R	Nm/rad.	0,34 x 10 ⁵	0,60 x 10 ⁵	0,98 x 10 ⁵	1,25 x 10 ⁵	1,25 x 10 ⁵	1,72 x 10 ⁵	1,72 x 10 ⁵	3,02 x 10 ⁵	2,47 x 10 ⁵	3,02 x 10 ⁵	2,47 x 10 ⁵	
0.03	L _{f min}	mm	221	239	282	310	322	379	369	423	449	423	449	
	G	kg	4,1	5,8	8,6	8,6	9,8	18,0	19,6	22,8	21,0	23,4	21,6	
	J _m	kgm ²	0,0038	0,0085	0,0129	0,0238	0,0238	0,04	-	0,066	0,0628	0,076	0,0728	
	C	Nm/rad.	0,44 x 10 ⁵	0,86 x 10 ⁵	1,44 x 10 ⁵	1,74 x 10 ⁵	1,74 x 10 ⁵	1,81 x 10 ⁵	-	3,35 x 10 ⁵	2,78 x 10 ⁵	3,35 x 10 ⁵	2,78 x 10 ⁵	
9.01	L _{z min}	mm	296	322	361	379	391	510	500	505	525	505	525	
	L _{a min}	mm	38	41	36	36	36	70	70	70	60	70	60	
	L _{z max}	mm	348	381	425	453	465	550	540	545	645	545	645	
	L _{a max}	mm	90	100	100	110	110	110	110	110	180	110	180	
9.03	L _{z min}	mm	245	274	313	331	343	419	409	441	-	441	-	
	L _{a min}	mm	25	27	28	29	29	45	45	45	-	45	-	
	L _{z max}	mm	280	317	355	397	409	484	474	506	-	506	-	
	L _{a max}	mm	60	70	70	95	95	110	110	110	-	110	-	
9.04	L _{f min}	mm	192	216	280	288	312	380	360	408	408	408	408	

L_{z min} = Shortest possible compressed length
 L_a = Length compensation
 L_{f min} = Shortest fixed length
 L_z + L_a = Maximum operating length

G = Weight of shaft
 G_R = Weight per 1.000 mm tube
 J_m = Moment of inertia
 J_{mR} = Moment of inertia per 1.000 mm tube

C = Torsional stiffness of shaft without tube
 C_R = Torsional stiffness per 1.000 mm tube

Data sheet series 687/688

0.02 with length compensation, tubular design
 0.03 without length compensation, tubular design
 9.01 with length compensation, short design

9.03 with length compensation, short design
 9.04 without length compensation, double flange shaft design

Design

0.02

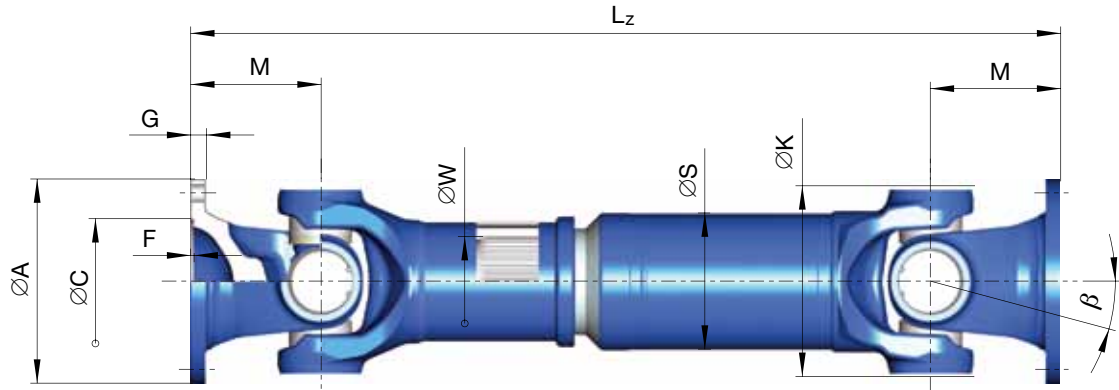

Shaft size		687/688.45			687/688.55			687/688.65	
T _{CS}	kNm	17			25			35	
T _{DW}	kNm	5,1			7,3			11	
L _c	-	0,104			0,236			0,837	
β	°	25	35	25	25	35	25	25	25
A	mm	180	180	225	180	180	225	180	225
K	mm	174	174	174	178	178	178	204	204
B ± 0,1 mm	mm	155,5	155,5	196	155,5	155,5	196	155,5	196
C H7	mm	110	110	140	110	110	140	110	140
F ¹⁾	mm	3	3	5	3	3	5	3	5
G	mm	12	12	15	14	14	15	15	15
H + 0,2 mm	mm	14,1	14,1	16,1	16,1	16,1	16,1	16,1	16,1
I ²⁾	-	8	8	8	10	10	8	10	8
M	mm	95	95	90	115	115	95	110	110
S	mm	120 x 4	110 x 5	120 x 4	120 x 6	120 x 6	120 x 6	142 x 6	142 x 6
W DIN 5480	mm	68 x 1,75			78 x 2			88 x 2,5	

T_{CS} = Functional limit torque*
 If the permissible functional limit torque T_{CS} is to be fully utilized, the flange connection must be reinforced.

T_{DW} = Reversing fatigue torque*
L_c = Bearing capacity factor*
 * See specifications of driveshafts.
 β = Maximum deflection angle per joint

Tubular shafts with welded-on balancing plates have lower fatigue torques T_{DW}
 1) Effective spigot depth
 2) Number of flange holes

Data sheet series 687/688

Design

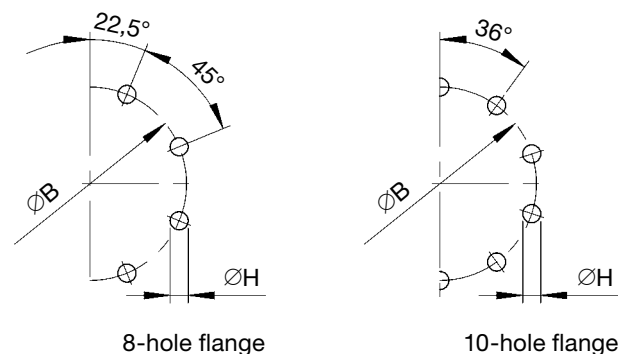
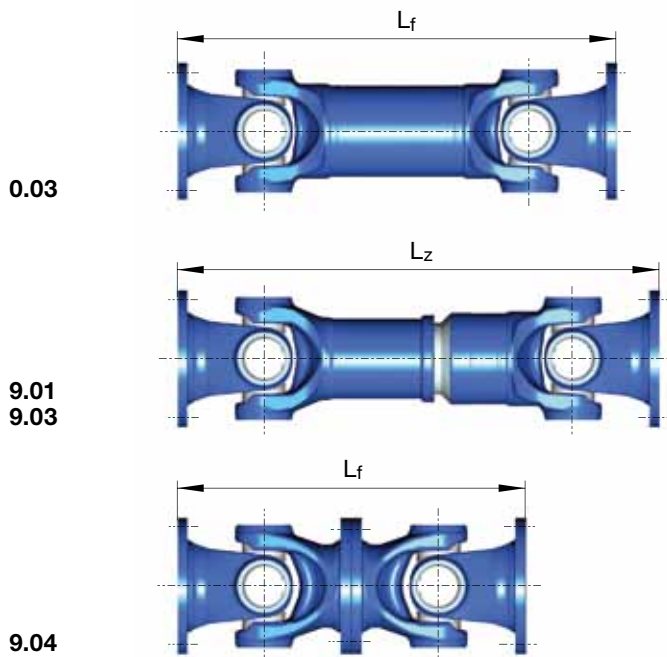

**NOTE: Hole patterns not optional.
Each driveshaft size has a specific hole pattern.**

Design	Shaft size	687/688.45			687/688.55			687/688.65		
0.02	L _{z min}	mm	595	703	585	662	681	622	686	686
	L _a	mm	110	180	110	110	110	110	110	110
	G	kg	35,7	38,4	37,7	44,0	49,2	47,0	60,6	64,6
	G _R	kg	11,44	12,95	11,44	16,86	16,86	16,86	20,12	20,12
	J _m	kgm ²	0,1002	0,1242	0,1342	0,131	-	0,151	0,2224	0,2614
	J _{mR}	kgm ²	0,0385	0,0357	0,0385	0,055	-	0,055	0,0932	0,0932
	C	Nm/rad.	3,10 x 10 ⁵	2,18 x 10 ⁵	3,10 x 10 ⁵	4,05 x 10 ⁵	-	4,05 x 10 ⁵	5,63 x 10 ⁵	5,63 x 10 ⁵
C _R	Nm/rad.	3,93 x 10 ⁵	3,65 x 10 ⁵	3,93 x 10 ⁵	5,60 x 10 ⁵	5,60 x 10 ⁵	5,60 x 10 ⁵	9,50 x 10 ⁵	9,50 x 10 ⁵	
0.03	L _{f min}	mm	425	425	415	475	495	435	491	491
	G	kg	28,0	27,8	30	33,1	-	36,1	47,3	51,3
	J _m	kgm ²	0,0954	0,0976	0,1294	0,1176	-	0,1376	0,2032	0,2422
	C	Nm/rad.	4,82 x 10 ⁵	3,71 x 10 ⁵	4,82 x 10 ⁵	5,39 x 10 ⁵	-	5,39 x 10 ⁵	7,17 x 10 ⁵	7,17 x 10 ⁵
9.01	L _{z min}	mm	517	538	507	587	606	547	601	601
	L _{a min}	mm	70	60	70	70	70	70	70	70
	L _{z max}	mm	557	658	547	617	636	577	641	641
	L _{a max}	mm	110	180	110	100	100	100	110	110
9.03	L _{z min}	mm	447	-	437	513	-	473	524	524
	L _{a min}	mm	50	-	50	50	-	50	50	50
	L _{z max}	mm	507	-	497	563	-	523	584	584
	L _{a max}	mm	110	-	110	110	-	110	110	110
9.04	L _{f min}	mm	380	380	360	460	460	380	440	440

L_{z min} = Shortest possible compressed length
L_a = Length compensation
L_{f min} = Shortest fixed length
L_z + L_a = Maximum operating length

G = Weight of shaft
G_R = Weight per 1.000 mm tube
J_m = Moment of inertia
J_{mR} = Moment of inertia per 1.000 mm tube

C = Torsional stiffness of shaft without tube
C_R = Torsional stiffness per 1.000 mm tube

Data sheet series 587

0.01 with length compensation, tubular design
 0.02 with large length compensation, tubular design
 0.03 without length compensation, tubular design

9.01 with length compensation, short design
 9.02 with length compensation, short design
 9.03 with length compensation, short design
 9.04 without length compensation, double flange shaft design

Design

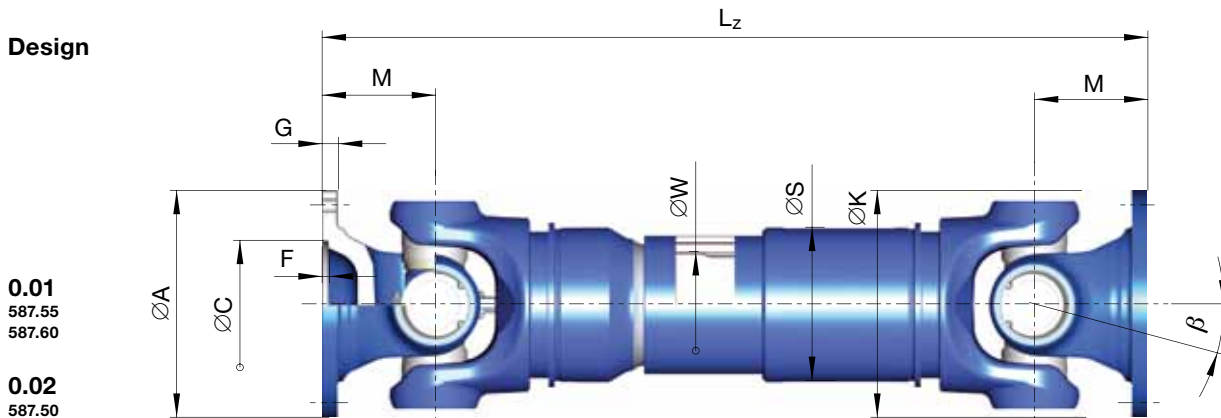

Shaft size		587.50		587.55		587.60	
T _{CS}	kNm	43		57		57	
T _{DW}	kNm	13		23		23	
L _c	-	1,84		(12,2)		24,8	
β	°	24	24	20	20	20	20
A	mm	225	250	250	285	285	285
K	mm	215	215	250	250	265	265
B ± 0,1 mm	mm	196	218	218	245	245	245
B _s ± 0,1 mm	mm	-	214	214	-	240	-
C H7	mm	140	140	140	175	175	175
F ¹⁾	mm	4,4	5,4	5,5	6,0	6,0	6,0
G	mm	15	18	18	20	20	20
H + 0,2 mm	mm	16,1	18,1	18,1	20,1	20,1	20,1
H _s H12	mm	-	25	25	-	28	-
I ²⁾	-	8	8	8	8	8	8
I _s ³⁾	-	-	4	4	-	4	-
M	mm	108	108	125	125	135	135
S	mm	144 x 7	144 x 7	167,7 x 9,8	167,7 x 9,8	167,7 x 9,8	167,7 x 9,8
W DIN 5480	mm	90 x 2,5	90 x 2,5	115 x 2,5	115 x 2,5	115 x 2,5	115 x 2,5

T_{CS} = Functional limit torque*
 If the permissible functional limit torque T_{CS} is to be fully utilized, the flange connection (e.g., with dowel pins) must be reinforced.
 Yield torque 30% over T_{CS}

T_{DW} = Reversing fatigue torque*
L_c = Bearing capacity factor*
 * See specifications of driveshafts.
 β = Maximum deflection angle per joint

1) Effective spigot depth
 2) Number of flange holes (standard flange connection)
 3) Number of flange holes (dowel pin connection)

Data sheet series 587

Design

0.03

9.01

9.02

9.03

9.04

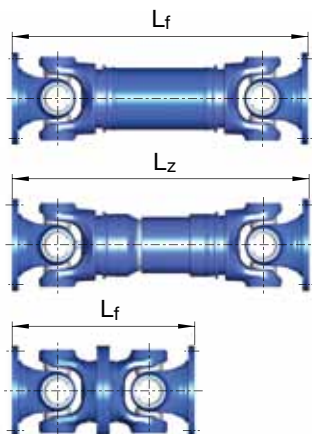

Standard flange connection

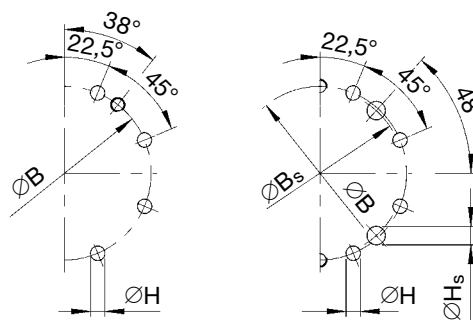

8-hole flange

8-hole flange

Dowel pin connection according to DIN 15451

Design	Shaft size	587.50				587.55				587.60												
0.01	L_z min	mm	-				840				840				870							
	L_a	mm	-				100				100				100							
	G	kg	-				120				125				132							
	G_R	kg	-				38,2				38,2				38,2							
	Jm	kgm ²	-				0,657				0,737				0,950							
	J_{mR}	kgm ²	-				0,239				0,239				0,239							
	C	Nm/rad.	-				$8,7 \times 10^5$				$8,7 \times 10^5$				$9,6 \times 10^5$							
	C_R	Nm/rad.	-				$24,3 \times 10^5$				$24,3 \times 10^5$				$24,3 \times 10^5$							
0.02*	L_z min	mm	800				800				960				960				990			
	L_a min	mm	110				110				200				200				200			
	G	kg	86				91				157				162				170			
	G_R	kg	23,7				23,7				38,2				38,2				38,2			
	Jm	kgm ²	0,325				0,361				-				-				-			
	J_{mR}	kgm ²	0,111				0,111				0,239				0,239				0,239			
	C	Nm/rad.	$5,29 \times 10^5$				$5,29 \times 10^5$				-				-				-			
	C_R	Nm/rad.	$11,33 \times 10^5$				$11,33 \times 10^5$				$24,3 \times 10^5$				$24,3 \times 10^5$				$24,3 \times 10^5$			
0.03	L_f	mm	540				540				610				610				640			
	G	kg	72				77				90				95				103			
	G_R	kg	23,7				23,7				38,2				38,2				38,2			
	Jm	kgm ²	0,270				0,306				0,547				0,627				0,84			
	J_{mR}	kgm ²	0,111				0,111				0,239				0,239				0,239			
	C	Nm/rad.	$7,2 \times 10^5$				$7,2 \times 10^5$				$9,8 \times 10^5$				$9,8 \times 10^5$				$11,5 \times 10^5$			
	C_R	Nm/rad.	$11,33 \times 10^5$				$11,33 \times 10^5$				$24,3 \times 10^5$				$24,3 \times 10^5$				$24,3 \times 10^5$			
	9.01	L_z min	mm	-				-				815				815				843		
L_a		mm	-				-				100				100				100			
G		kg	-				-				110				115				142			
Jm		kgm ²	-				-				0,64				0,72				0,93			
C		Nm/rad.	-				-				$8,8 \times 10^5$				$8,8 \times 10^5$				$9,7 \times 10^5$			
9.02		L_z	mm	-				-				780				780				810		
	L_a	mm	-				-				65				65				70			
	G	kg	-				-				108				113				125			
9.03	L_z	mm	550	600	650	696	550	600	650	696	720				720				750			
	L_a	mm	60	75	90	110	60	75	90	110	65				65				65			
	G	kg	61	66	68	70	66	71	73	75	113				118				126			
9.04	L_f	mm	432				432				500				500				540			
	G	kg	58				68				81				91				110			

L_z min = Shortest possible compressed length

L_a = Length compensation

L_f min = Shortest fixed length

$L_z + L_a$ = Maximum operating length

G = Weight of shaft

G_R = Weight per 1.000 mm tube

Jm = Moment of inertia

J_{mR} = Moment of inertia per 1.000 mm tube

C = Torsional stiffness of shaft without tube

C_R = Torsional stiffness per 1.000 mm tube

* Larger length compensation available on request

Data sheet series 390 Maximum bearing life

0.01 with length compensation, tubular design
 0.02 with large length compensation, tubular design
 0.03 without length compensation, tubular design

9.01 with length compensation, short design
 9.02 with length compensation, short design
 9.03 with length compensation, short design
 9.04 without length compensation, double flange shaft design

Design

0.01

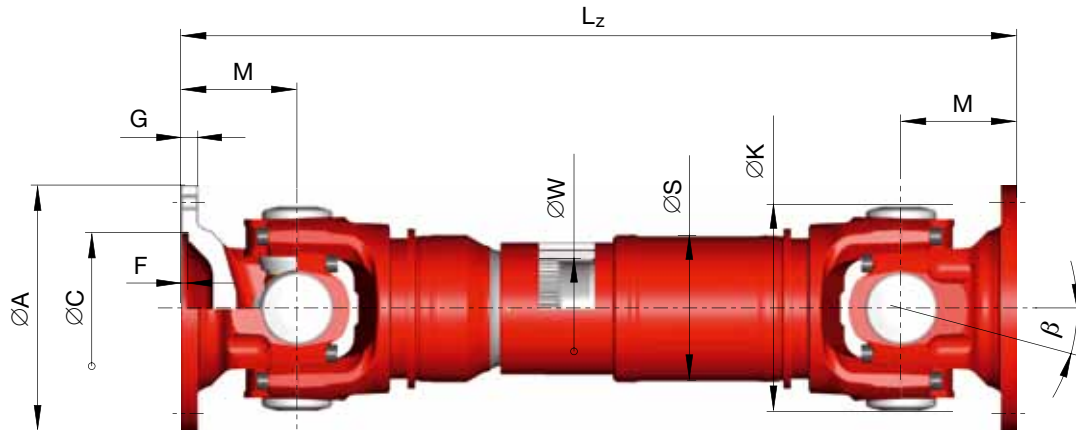

Shaft size		390.60	390.65	390.70	390.75	390.80
T _{CS}	kNm	60	90	130	190	255
T _{DW}	kNm	23	36	53	75	102
L _c	-	24,8	70,2	238	618	1563
β	°	15	15	15	15	15
A	mm	285	315	350	390	435
K	mm	240	265	300	330	370
B ± 0,1 mm	mm	245	280	310	345	385
B _s ± 0,1 mm	mm	240	270	300	340	378
C H7	mm	175	175	220	250	280
F ¹⁾	mm	6	6	7	7	9
G	mm	20	22	25	28	32
H ⁴⁾	mm	20,1	22,1	22,1	24,1	27,1
H _s H12	mm	28	30	32	32	35
I ²⁾	-	8	8	10	10	10
I _s ³⁾	-	4	4	4	4	4
M	mm	135	150	170	190	210
S	mm	167,7 x 9,8	218,2 x 8,7	219 x 13,3	273 x 11,6	273 x 19
W DIN 5480	mm	115 x 2,5	150 x 3	150 x 3	185 x 5	185 x 5

T_{CS} = Functional limit torque*
 If the permissible functional limit torque T_{CS} is to be fully utilized, the flange connection (e.g., with dowel pins) must be reinforced. Yield torque 30% over T_{CS}

T_{DW} = Reversing fatigue torque*
L_c = Bearing capacity factor*
 * See specifications of driveshafts.
 β = Maximum deflection angle per joint

1) Effective spigot depth
 2) Number of flange holes (standard flange connection)
 3) Number of flange holes (dowel pin connection)
 4) 390.60 - 390.70 + 0,2 mm
 390.75 - 390.80 + 0,5 mm

Data sheet series 390 Maximum bearing life

Design

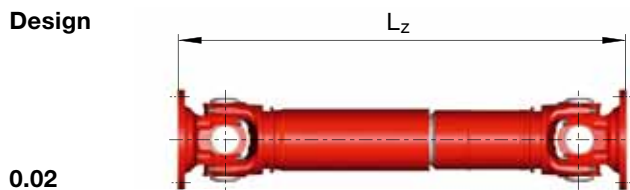

0.02

9.01
9.02
9.03

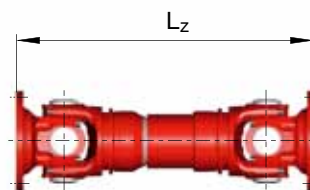

0.03

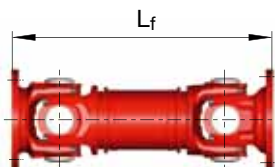

9.04

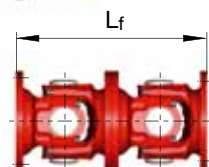

Standard flange connection

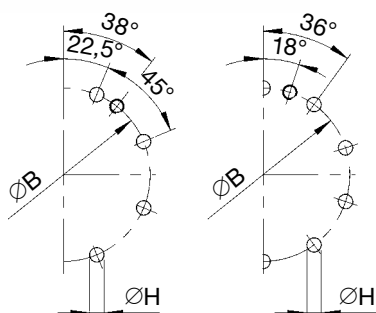

8-hole flange

10-hole flange

Dowel pin connection according to DIN 15451

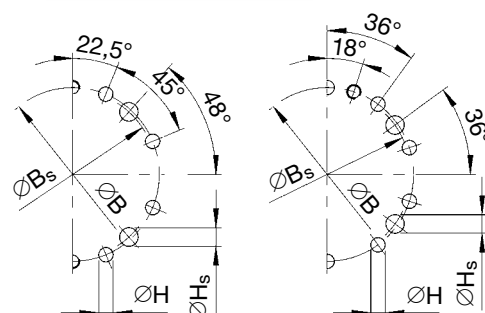

8-hole flange

10-hole flange

NOTE: Each driveshaft size has a specific hole pattern (see table). Other hole patterns available on request.

Design	Shaft size		390.60	390.65	390.70	390.75	390.80
0.01	L _{z min}	mm	870	980	1.070	1.210	1.280
	L _a	mm	100	135	135	170	170
	G	kg	138	216	276	405	490
	G _R	kg	38,2	45,0	67,5	74,8	119
	J _m	kgm ²	1,04	1,61	2,51	4,20	8,20
	J _{mR}	kgm ²	0,239	0,494	0,716	1,28	1,93
	C	Nm/rad.	1,0 x 10 ⁶	1,65 x 10 ⁶	2,43 x 10 ⁶	3,3 x 10 ⁶	4,7 x 10 ⁶
	C _R	Nm/rad.	2,43 x 10 ⁶	5,04 x 10 ⁶	7,3 x 10 ⁶	1,3 x 10 ⁷	1,96 x 10 ⁷
0.02*	L _{z min}	mm	990	1.080	1.170	1.295	1.365
	L _{a min}	mm	200	220	220	250	250
	G	kg	178	280	337	508	586
	G _R	kg	38,2	45,0	67,5	74,8	119
0.03	L _{f min}	mm	640	710	800	890	960
	G	kg	109	159	218	302	385
	G _R	kg	38,2	45,0	67,5	74,8	119
9.01	L _z	mm	843	953	1.043	1.175	1.245
	L _a	mm	100	135	135	170	170
	G	kg	136	213	273	402	482
9.02	L _z	mm	810	890	980	1.100	1.170
	L _a	mm	70	75	75	95	95
	G	kg	135	198	261	375	456
9.03	L _z	mm	750	835	925	1.030	1.100
	L _a	mm	65	75	75	85	85
	G	kg	135	202	264	371	453
9.04	L _f	mm	540	600	680	760	840
	G	kg	108	146	210	284	380

L_{z min} = Shortest possible compressed length

L_a = Length compensation

L_{f min} = Shortest fixed length

L_z + L_a = Maximum operating length

G = Weight of shaft

G_R = Weight per 1.000 mm tube

J_m = Moment of inertia

J_{mR} = Moment of inertia per 1.000 mm tube

C = Torsional stiffness of shaft without tube

C_R = Torsional stiffness per 1.000 mm tube

* Larger length compensation available on request

Data sheet series 392/393 High torque capacity

0.01 with length compensation, tubular design
 0.02 with large length compensation, tubular design
 0.03 without length compensation, tubular design

9.01 with length compensation, short design
 9.02 with length compensation, short design
 9.03 with length compensation, short design
 9.04 without length compensation, double flange shaft design

Design

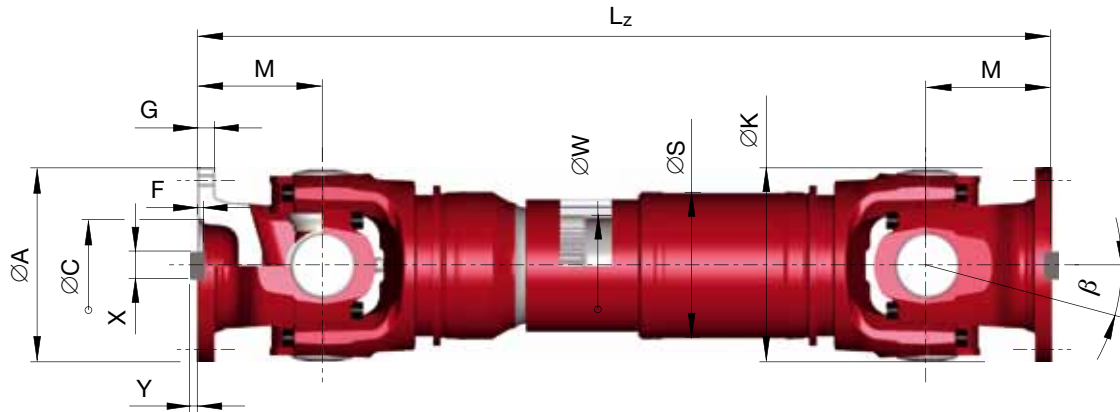

0.01

Shaft size		392.50	392.55	392.60	392.65	392.70	393.75	393.80	393.85	393.90
T _{CS}	kNm	70	105	150	215	295	390	580	750	1.150
T _{DW}	kNm	23	36	53	75	102	140	220	285	435
L _c	-	7,6	25,2	82,6	261	684	1.700	7.070	15.600	62.600
β	°	15	15	15	15	15	10	10	10	10
A	mm	225	250	285	315	350	390	435	480	550
K	mm	225	250	285	315	350	390	435	480	550
B	mm	196	218	245	280	310	345	385	425	492
C H7	mm	105	105	125	130	155	170	190	205	250
F ¹⁾	mm	4,5	5	6	7	7	8	10	12	12
G	mm	20	25	27	32	35	40	42	47	50
H	mm	17	19	21	23	23	25	28	31	31
i ²⁾	-	8	8	8	10	10	10	16	16	16
M	mm	145	165	180	205	225	205	235	265	290
S	mm	167,7 x 9,8	218,2 x 8,7	219 x 13,3	273 x 11,6	273 x 19	273 x 36	323,9 x 36	355,6 x 40	406,4 x 45
X e9	mm	32	40	40	40	50	70	80	90	100
Y	mm	9	12,5	15	15	16	18	20	22,5	22,5
W DIN 5480	mm	115 x 2,5	150 x 3	150 x 3	185 x 5	185 x 5	185 x 5	210 x 5	240 x 5	240 x 5

T_{CS} = Functional limit torque*
 Yield torque 30% over T_{CS}

T_{DW} = Reversing fatigue torque*
 L_c = Bearing capacity factor*

* See specifications of driveshafts.
 β = Maximum deflection angle per joint

1) Effective spigot depth
 2) Number of flange holes

Data sheet series 392/393 High torque capacity

Design

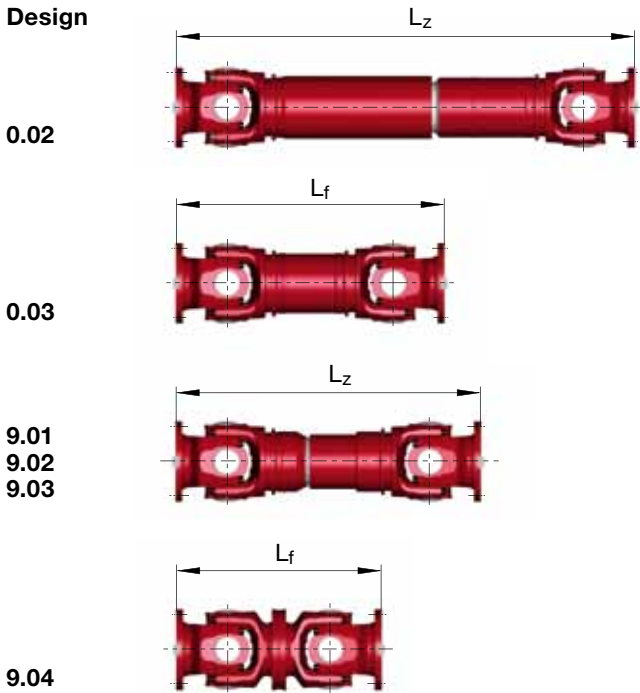

Flange connection with face key

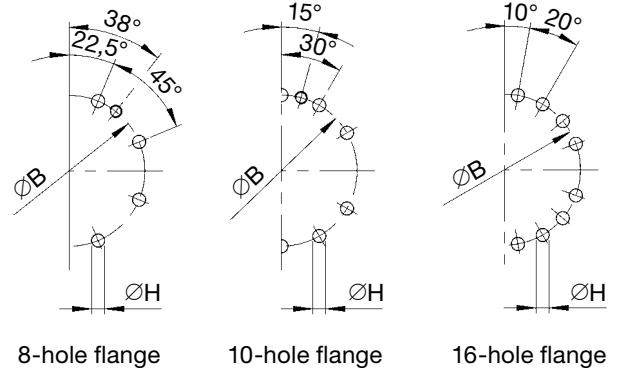

Each driveshaft size has a specific hole pattern (see table). Other hole patterns available on request.

Design	Shaft size	392.50	392.55	392.60	392.65	392.70	393.75	393.80	393.85	393.90	
0.01	L _{z min}	mm	890	1.010	1.090	1.240	1.310	1.430	1.620	1.820	2.035
	L _a	mm	100	135	135	170	170	170	170	190	210
	G	kg	129	214	272	406	493	732	1.055	1.477	2.209
	G _R	kg	38,2	45	67,5	74,8	119	210,4	255,6	311,3	401,1
	J _m	kgm ²	1,02	1,43	2,23	3,80	6,5	11,72	17,84	25,26	40,76
	J _{mR}	kgm ²	0,239	0,494	0,716	1,28	1,93	3,02	5,38	7,87	13,3
	C	Nm/rad.	9,5 x 10 ⁵	1,42 x 10 ⁶	2,36 x 10 ⁶	3,1 x 10 ⁶	4,4 x 10 ⁶	5,19 x 10 ⁶	7,86 x 10 ⁶	1,09 x 10 ⁷	1,43 x 10 ⁷
	C _R	Nm/rad.	2,43 x 10 ⁶	5,06 x 10 ⁶	7,3 x 10 ⁶	1,3 x 10 ⁷	1,96 x 10 ⁷	3,08 x 10 ⁷	5,48 x 10 ⁷	8,03 x 10 ⁷	1,36 x 10 ⁸
0.02*	L _{z min}	mm	1.010	1.110	1.190	1.325	1.395	1.570	1.780	1.975	2.190
	L _{a min}	mm	200	220	220	250	250	310	330	350	365
	G	kg	171	275	331	515	603	796	1.158	1.648	2.367
	G _R	kg	38,2	45	67,5	74,8	119	210,4	255,6	311,3	401,1
0.03	L _{f min}	mm	660	740	820	920	990	977	1.110	1.240	1.380
	G	kg	101	156	215	301	389	538	748	1.052	1.600
	G _R	kg	38,2	45	67,5	74,8	119	210,4	255,6	311,3	401,1
9.01	L _z	mm	863	983	1.063	1.205	1.275	1.363	1.550	1.750	1.955
	L _a	mm	100	135	135	170	170	170	170	190	210
	G	kg	130	210	269	402	487	718	1.037	1.446	2.177
9.02	L _z	mm	830	920	1.000	1.130	1.200	1.300	1.400	1.630	1.770
	L _a	mm	70	75	75	95	95	90	90	100	100
	G	kg	124	204	263	375	466	641	876	1.325	1.717
9.03	L _z	mm	770	865	945	1.060	1.130	1.200	1.300	1.520	1.680
	L _a	mm	65	75	75	85	85	70	70	150	80
	G	kg	123	197	260	371	457	602	832	1.000	1.657
9.04	L _f	mm	580	660	720	820	900	820	940	1.060	1.160
	G	kg	94	145	207	288	391	485	653	890	1.443

L_{z min} = Shortest possible compressed length
 L_a = Length compensation
 L_{f min} = Shortest fixed length
 L_z + L_a = Maximum operating length

G = Weight of shaft
 G_R = Weight per 1.000 mm tube
 J_m = Moment of inertia
 J_{mR} = Moment of inertia per 1.000 mm tube

C = Torsional stiffness of shaft without tube
 C_R = Torsional stiffness per 1.000 mm tube
 * Larger length compensation available on request

Data sheet series 492 Maximum torque capacity

- 0.01 with length compensation, tubular design
- 0.03 without length compensation, tubular design
- 9.01 with length compensation, short design

- 9.02 with length compensation, short design
- 9.03 with length compensation, short design
- 9.04 without length compensation, double flange shaft design

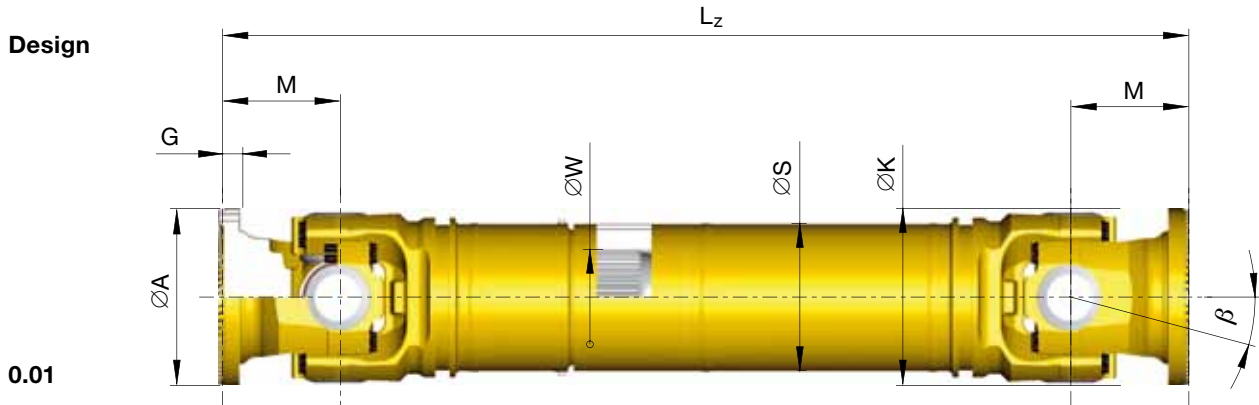

Shaft size		492.60	492.65	492.70	492.75		492.80		492.85		492.90	
T_{CS}	kNm	210	250	340	440	410	650	580	850	770	1.300	1.170
T_{DW}	kNm	100	115	160	210	190	280	250	400	360	600	540
L_c	-	107	332	860	2.060		7.390		17.400		60.120	
β	°	7	7	7	10	15	10	15	10	15	10	15
A	mm	285	315	350	390		435		480		550	
K	mm	285	315	350	390		435		480		550	
B	mm	255	280	315	350		395		445		510	
G	mm	35	35	40	45		50		55		65	
H	mm	15	17	17	19		19		21		23	
l¹⁾	-	10	10	12	12		16		16		16	
M	mm	200	220	240	260		280		300		330	
S	mm	244,5 x 22,2		244,5 x 28	273 x 30		323,9 x 36		355,6 x 40		406,4 x 40	
W <i>DIN 5480</i>	mm	185 x 5		185 x 5	210 x 5		210 x 5		210 x 5		240 x 5	

T_{CS} = Functional limit torque*
 Yield torque 30% over T_{CS}
T_{DW} = Reversing fatigue torque*
L_c = Bearing capacity factor*

* See specifications of driveshafts.
 β = Maximum deflection angle per joint
 1) Number of flange holes

Data sheet series 492 Maximum torque capacity

Design

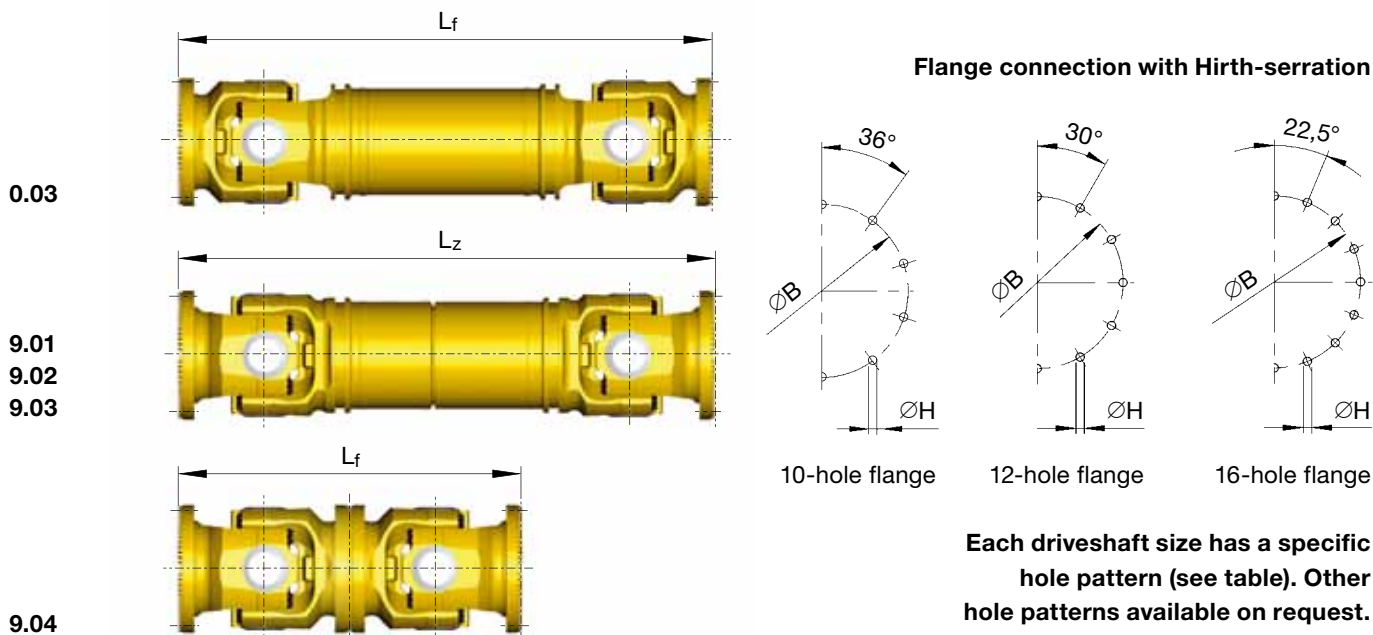

Design	Shaft size		492.60	492.65	492.70	492.75	492.80	492.85	492.90
0.01	L _{z min}	mm	1.440	1.520	1.680	1.750	1.900	2.130	2.415
	L _a	mm	135	135	150	170	170	190	210
	G	kg	472	568	788	1.025	1.355	1.873	2.750
	G _R	kg	121	149	180	255,6	311,3	361,4	501,94
	J _m	kgm ²	4,16	5,16	7,73	15	30,7	50,4	92,7
	J _{mR}	kgm ²	1,52	1,78	2,69	5,38	7,88	12,28	21,1
	C	Nm/rad.	3,32 x 10 ⁶	4,31 x 10 ⁶	5,97 x 10 ⁶	6,76 x 10 ⁶	9,7 x 10 ⁶	13,64 x 10 ⁶	19,44 x 10 ⁶
	C _R	Nm/rad.	1,55 x 10 ⁷	1,82 x 10 ⁷	2,75 x 10 ⁷	5,48 x 10 ⁷	8,03 x 10 ⁷	12,51 x 10 ⁷	21,5 x 10 ⁷
0.03	L _{f min}	mm	940	1.020	1.130	1.220	1.320	1.450	1.620
	G	kg	311	407	557	819	1.040	1.330	1.880
	G _R	kg	121	149	180	255,6	311,3	361,4	501,9
9.01	L _z	mm	1.380	1.460	1.620	1.700	1.840	2.050	2.340
	L _a	mm	135	135	150	170	170	190	210
	G	kg	465	559	777	1.010	1.340	1.850	2.710
9.04	L _f	mm	800	880	960	1.040	1.120	1.200	1.320
	G	kg	286	374	514	780	1.000	1.300	1.830

L_{z min} = Shortest possible compressed length
 L_a = Length compensation
 L_{f min} = Shortest fixed length
 L_z + L_a = Maximum operating length

G = Weight of shaft
 G_R = Weight per 1.000 mm tube
 J_m = Moment of inertia
 J_{mR} = Moment of inertia per 1.000 mm tube

C = Torsional stiffness of shaft without tube
 C_R = Torsional stiffness per 1.000 mm tube

Length dimensions (L_z/L_a) of the designs 0.02 · 9.02 · 9.03 available on request.

Data sheet series 498

0.01 with length compensation, tubular design
 0.03 without length compensation, tubular design

9.04 without length compensation, double flange shaft design

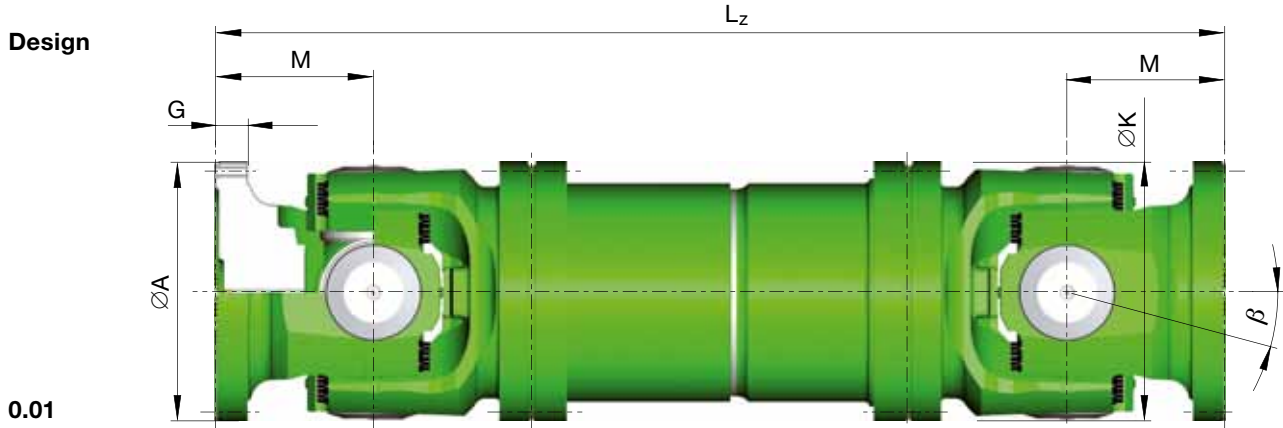

Shaft size		498.00			498.05			498.10			498.15		
T _{CS}	kNm	1.880	1.620	1.430	2.340	2.080	1.750	3.000	2.600	2.200	3.640	3.100	2.700
T _{DW}	kNm	900	780	680	1.120	1.000	840	1.430	1.250	1.050	1.750	1.500	1.300
L _c	-	0,115	0,144	0,154	0,224	0,322	0,343	0,530	0,684	0,720	1,09	1,35	1,43
		x 10 ⁶	x 10 ⁶	x 10 ⁶	x 10 ⁶	x 10 ⁶	x 10 ⁶	x 10 ⁶	x 10 ⁶	x 10 ⁶	x 10 ⁶	x 10 ⁶	x 10 ⁶
β	°	5	10	15	5	10	15	5	10	15	5	10	15
A	mm	600			650			700			750		
K	mm	600			650			700			750		
B	mm	555			605			655			695		
G	mm	75			80			90			95		
H	mm	26			26			26			32		
I ¹⁾	-	20			20			24			24		
M	mm	370	370	390	390	390	410	420	420	440	460	460	480

Shaft size		498.20			498.25			498.30			498.35		
T _{CS}	kNm	4.420	3.800	3.300	5.300	4.500	4.050	6.300	5.400	4.700	7.400	6.500	5.600
T _{DW}	kNm	2.120	1.850	1.600	2.550	2.200	1.950	3.050	2.650	2.250	3.500	3.100	2.700
L _c	-	1,69	2,14	2,55	3,26	4,01	4,681	7,05	7,86	8,29	9,71	10,7	14,24
		x 10 ⁶	x 10 ⁶	x 10 ⁶	x 10 ⁶	x 10 ⁶	x 10 ⁶	x 10 ⁶	x 10 ⁶	x 10 ⁶	x 10 ⁶	x 10 ⁶	x 10 ⁶
β	°	5	10	15	5	10	15	5	10	15	5	10	15
A	mm	800			850			900			950		
K	mm	800			850			900			950		
B	mm	745			785			835			885		
G	mm	100			105			110			120		
H	mm	32			38			38			38		
I ¹⁾	-	24			24			24			24		
M	mm	480	480	500	530	530	555	555	555	580	580	580	610

T_{CS} = Functional limit torque*
 Yield torque 30% over T_{CS}
 T_{DW} = Reversing fatigue torque*
 L_c = Bearing capacity factor*

* See specifications of driveshafts.
 β = Maximum deflection angle per joint
 1) Number of flange holes

Data sheet series 498

Design

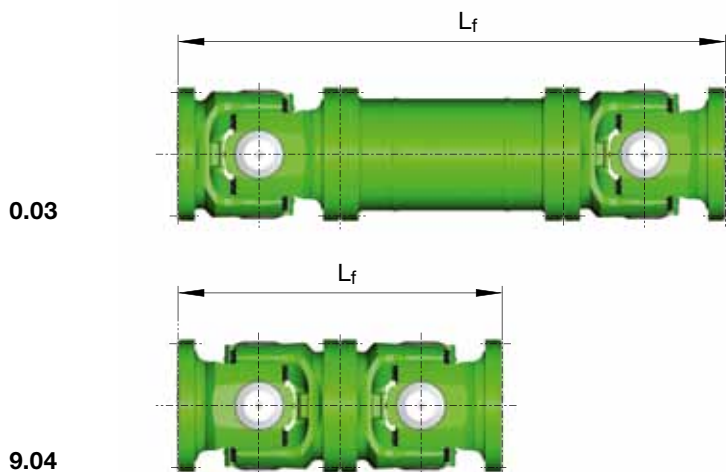

Flange connection with Hirth-serration

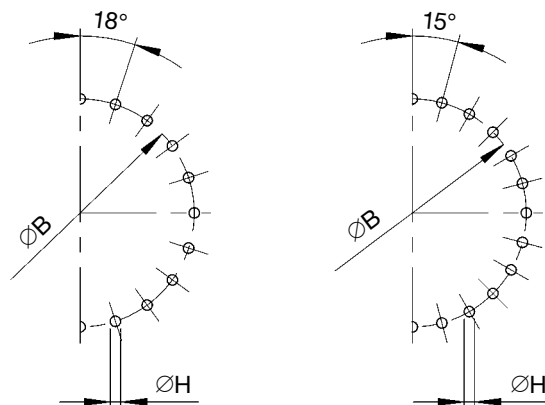

20-hole flange

24-hole flange

Each driveshaft size has a specific hole pattern (see table). Other hole patterns available on request.

Shaft size		498.40			498.45			498.50			498.55			498.60		
T _{CS}	kNm	8.700	7.500	6.500	10.000	8.700	7.500	11.500	10.000	8.600	13.200	11.400	9.900	15.000	13.000	11.200
T _{DW}	kNm	4.200	3.600	3.100	4.800	4.200	3.600	5.500	4.800	4.100	6.300	5.500	4.700	7.200	6.200	5.400
L _c	-	16,1	17,4	23,78	24,4	28,71	38,73	36,4	42,63	61,67	56,3	70,8	96,19	89,9	102	147,2
		x 10 ⁶	x 10 ⁶	x 10 ⁶	x 10 ⁶	x 10 ⁶	x 10 ⁶	x 10 ⁶	x 10 ⁶	x 10 ⁶	x 10 ⁶	x 10 ⁶	x 10 ⁶	x 10 ⁶	x 10 ⁶	x 10 ⁶
β	°	5	10	15	5	10	15	5	10	15	5	10	15	5	10	15
A	mm	1.000			1.050			1.100			1.150			1.200		
K	mm	1.000			1.050			1.100			1.150			1.200		
B	mm	925			975			1.025			1.065			1.115		
G	mm	125			130			135			140			150		
H	mm	44			44			44			50			50		
l ¹⁾	-	20			20			20			20			20		
M	mm	625	625	655	645	645	675	670	670	700	715	715	745	740	740	775

GWB™ driveshaft series „598“ in fully forged design with maximum torque capacity are available on request.

Length dimensions (L_z/L_f/L_a) of the designs 0.01 · 0.03 · 9.04 available on request.

Data sheet series 587/190 Super short designs

9.06 driveshaft with length compensation,
super short design

Series 587

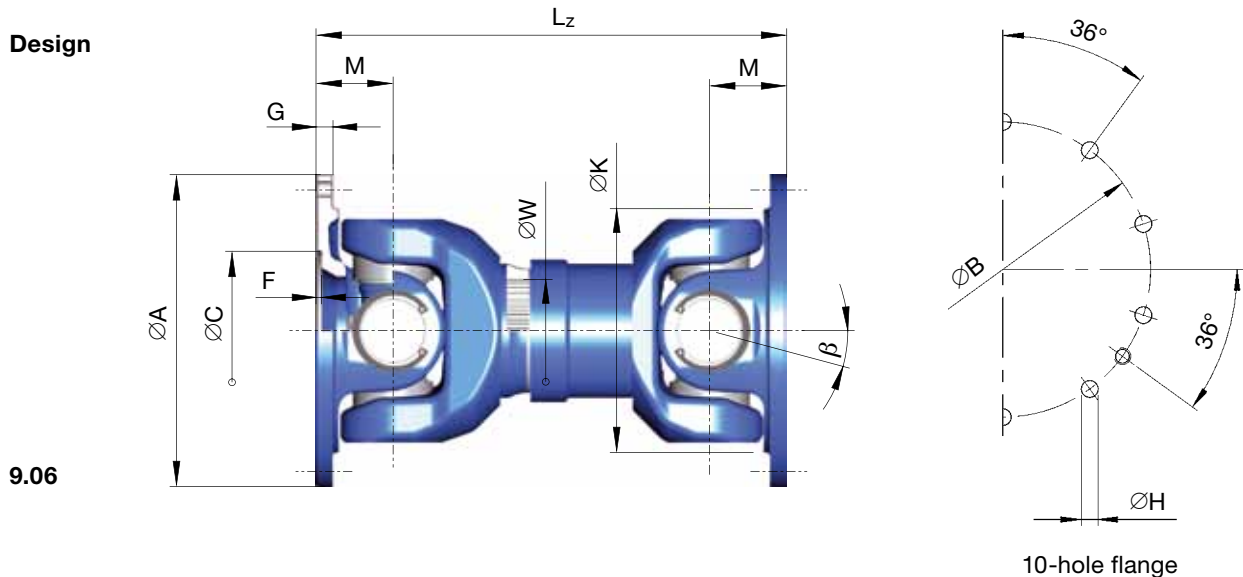

Shaft size		587.50	190.55	190.60	190.65	190.70
T_{CS}	kNm	43	33	48	68	130
T_{DW}	kNm	13	11	21	25	53
L_c	-	1,84	7,0	58,5	166	510
β	°	5	5	5	5	5
A	mm	275	305	348	360	405
K	mm	215	250	285	315	350
B ± 0,1 mm	mm	248	275	314	328	370
C H7	mm	140	140	175	175	220
F ¹⁾	mm	4,5	5,5	6	6	6,5
G	mm	15	15	18	18	22
H + 0,2 mm	mm	14,1	16,1	18,1	18,1	20,1
I ²⁾	-	10	10	10	10	10
M	mm	68	80	90	100	108
W DIN 5482/5480	mm	90 x 2,5	100 x 94	100 x 94	130 x 3	150 x 3

T_{CS} = Functional limit torque*
Yield torque 30% over T_{CS}
T_{DW} = Reversing fatigue torque*
L_c = Bearing capacity factor*

* See specifications of driveshafts.
β = Maximum deflection angle per joint
1) Effective spigot depth
2) Number of flange holes

Data sheet series 587/190 Super short designs

Series 190

Design

9.06

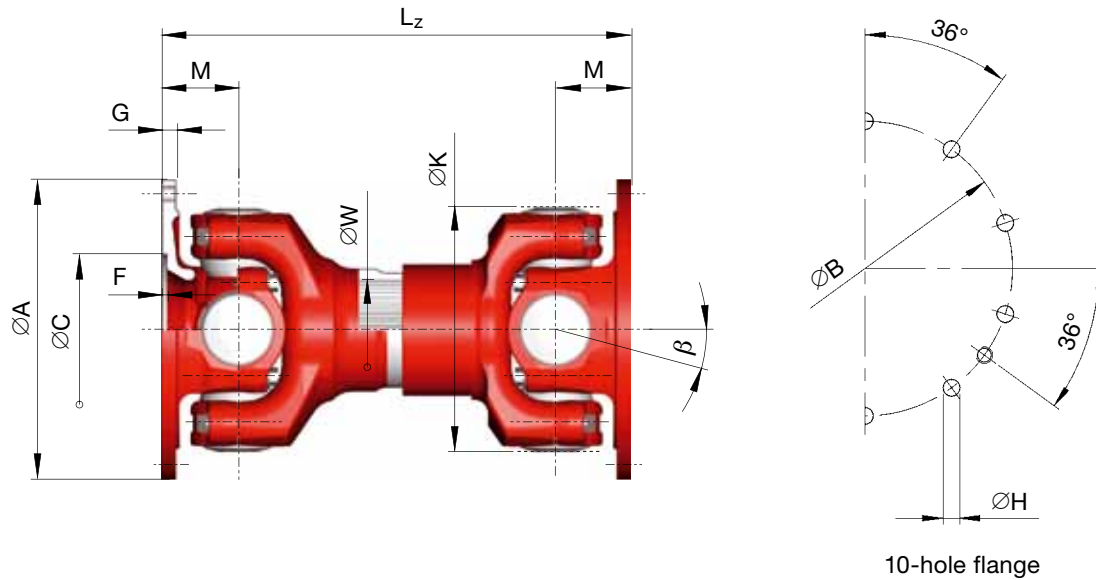

Design	Shaft size		587.50	190.55	190.60	190.65	190.70
9.06	L _z	mm	415	495	545	600	688
	L _a	mm	40	40	40	40	55
	G	kg	60	98	120	169	256
	J _m	kgm ²	0,33	0,624	1,179	2,286	3,785

L_z = Shortest compressed length
 L_a = Length compensation
 L_z + L_a = Maximum operating length

G = Weight of shaft
 J_m = Moment of inertia

Data sheet series 330 Quick release couplings

Design with spiral serration for higher speeds

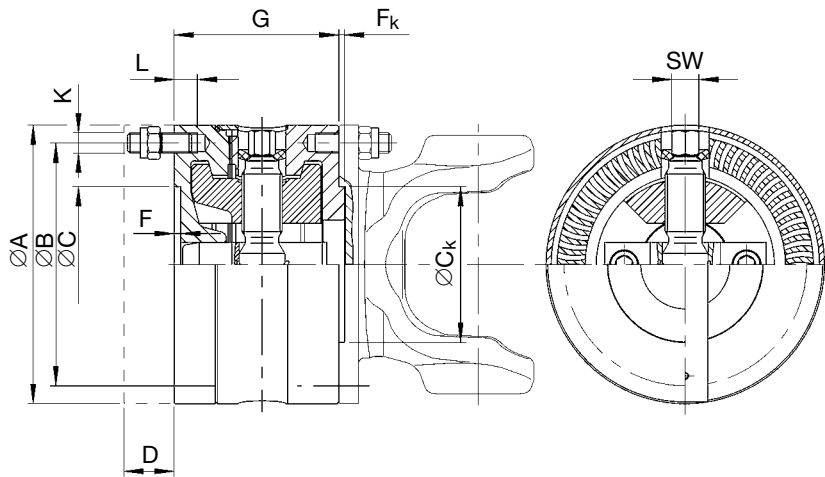

Connection for series 687/688
 Connection for series 587
 Connection for series 392
 with face key

For hole distribution, see data sheets of the corresponding driveshaft.

Coupling size			330.10	330.20	330.30	330.40	330.50			330.55		
Shaft connection			687/688.15	687/688.20	687/688.25 687/688.35	687/688.30 687/688.40	687/688.40 687/688.45	687/688.45 687/688.65	587.50	392.50	587.55	392.55
Model		Nr.	000	003	003	003		000		001	000	001
	A	mm	100	130	150	180		225		225	250	250
	B	mm	84	101,5	130	155,5		196		196	218	218
	C ¹⁾	mm	57	75	90	110		140		105	140	105
	C _k ¹¹⁾	mm	57	75	90	110		140		105	140	105
	D ²⁾	mm	20	38	40	40		45		45	45	45
	F	mm	2,5	2,5	3,5	4		5		5	6	6
	F _k	mm	2,3-0,2	2,3-0,15	2,3-0,2	2,3-0,15		4-0,2		4-0,2	5-0,2	5-0,2
	G	mm	76	100	100	112		144		144	148	162
	j ³⁾	-	6	8	8	8		8		8	8	8
	K ⁴⁾	-	M 8 x 18	M 10 x 22	M 12 x 25	M 14 x 28		M 16 x 35		M 16 x 40	M 18 x 40	M 18 x 45
	L ¹⁰⁾	mm	10	11	14	20		18		18	21	21
	G _k ¹²⁾	kg	4,7	7,5	10,6	16,4		34		36	40	49
Ta Nut		Nm	35	69	120	190		295		295	405	405
Extension ⁵⁾		Nr.	2.365/13 M	2.365/17 M	2.365/19 M	22 M		24 R		24 R	27 R	27 R
Ta Spindle		Nm	30	45	80	100		190		190	220	220
Socket wrench ⁶⁾		Nr.	1/2" D 19 SW 13		1/2" D 19 SW 17			1/2" D 19 SW 22				

Operating instructions

Engaging and disengaging the coupling

Engaging and disengaging are done by operating the threaded spindle located in the inner part of the coupling. The spindle can be reached from two sides and be operated. The spindle is tightened by means of a socket wrench (see table).

Notice:

1. Before engaging the coupling, make sure that the coupling teeth are properly fitted.

2. The engagement direction is marked by arrows. The spindle may be tightened either clockwise or counter-clockwise.

3. The joint with the coupling component falls back when disengaged. **Caution: Danger of injury!**

In case of a subsequent installation of the quick release coupling, the driveshaft must be correspondingly shorter. The threaded spindles of the coupling are lubricated by the supplier with MoS₂. Relubrication is recommended from time to time.

Data sheet series 230 Quick release couplings

Design with trapezoidal serration for speeds up to 1.000 rpm

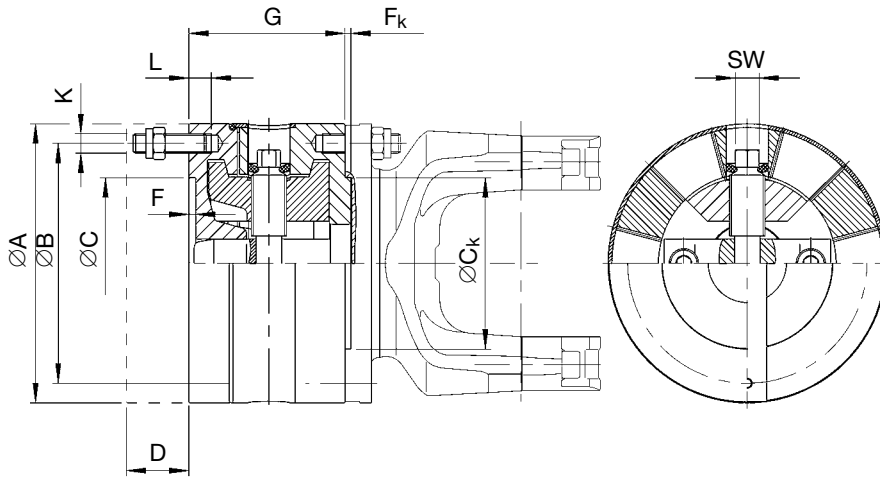

Connection for series 390
 Connection for series 392/393
 with face key

For hole distribution, see data sheets of the corresponding driveshaft.

Coupling size			230.60		230.65		230.70		230.75		230.80	
Shaft connection			390.60	392.60	390.65	392.65	390.70	392.70	390.75	393.75	390.80	393.80
Model		Nr.	000	001	000	001	000	001	000	001	000	001
	A	mm	285	285	315	315	350	350	390	390	435	435
	B	mm	245	245	280	280	310	310	345	345	385	385
	C ¹⁾	mm	175	125	175	130	220	155	250	170	280	190
	C _k ¹¹⁾	mm	175	125	175	130	220	155	250	170	280	190
	D ²⁾	mm	64	64	66	66	72	72	82	82	92	92
	F	mm	7	7	7	8	8	8	8	8	10	10
	F _k	mm	6-0,2	6-0,5	6-0,2	7-0,5	7-0,3	7-0,5	7-0,2	7-0,5	9-0,5	9-0,5
	G	mm	160	174	172	192	184	204	196	220	226	246
	I ³⁾	-	8	8	8	10	10	10	10	10	10	16
	K ⁴⁾	-	M 20 x 45	M 20 x 55	M 22 x 50	M 22 x 60	M 22 x 50	M 22 x 60	M 24 x 55	M 24 x 70	M 27 x 65	M 27 x 75
	L ¹⁰⁾	mm	23	23	25	25	25	25	27	27	30	30
	G _k ¹²⁾	kg	66	71	83	95	110	120	143	150	210	230
Ta Nut		Nm	580	580	780	780	780	780	1.000	1.000	1.500	1.500
Extension ⁵⁾		Nr.	30 R	30 R	32 R	32 R	32 R	32 R	36 R	36 R	41 R	41 R
Ta Spindle		Nm	290	290	400	400	550	550	680	680	950 ⁹⁾	950 ⁹⁾
Socket wrench ⁶⁾		Nr.	3/4" D 32 SW 22		3/4" D 32 SW 27		3/4" D 32 SW 27		3/4" D 32 SW 32		3/4" D 32 SW 36	
X = 4 spanners ⁸⁾		Nr.									TD 750	

- Spigot fit H7
- Disengaging movement for separation of the coupling
- Number of stud bolts per flange
- Dimensions of the bolt connections
Stud bolt DIN 938
Self-locking hexagon nut DIN 980
- Jaw or ring extension in accordance with Dana standard N 4.2.5
- Gedore socket spanner set for tightening the spindle
- Rahsol torque meter
- Force multiplier spanner x = 4 (TD 750)
- Adjusting moment of the torque wrench 756 C = 238 Nm
- Thread depth
- Fit h6 up to series 390
Fit f8 for series 392/393
- G_k = Weight of coupling
- Ta = Tightening torques of flange boltings and of the threaded coupling spindles

Torque wrench ⁷⁾	Torque range	
	from	to
756 B	20 Nm	100 Nm
756 C	80 Nm	300 Nm
756 D	280 Nm	760 Nm

For applications with speeds higher than 1.000 rpm, please contact Dana engineers. Other designs available on request.

Data sheet Journal cross assemblies (unit packs)

Design

7.06 journal cross, complete

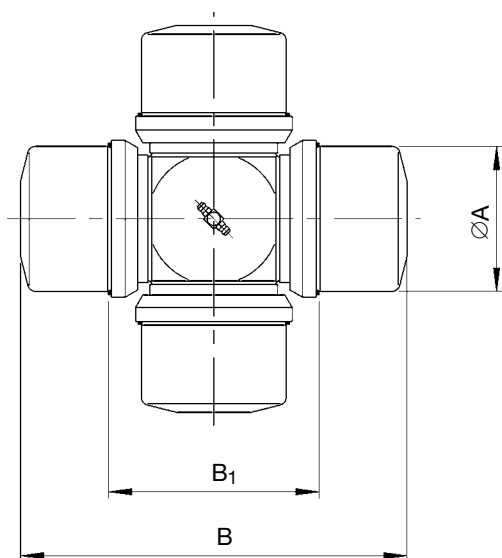
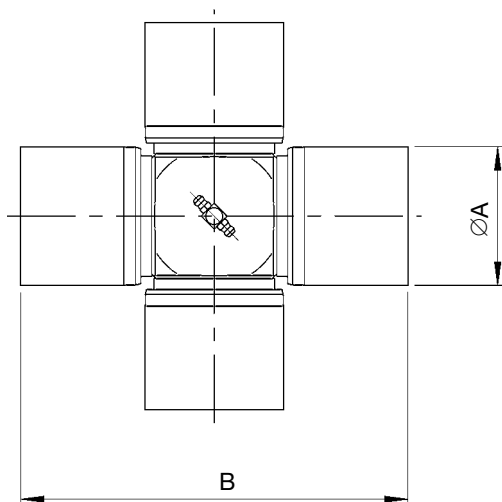

Journal cross assemblies are only supplied as complete units. For orders, please state shaft size or, if known, the drawing number of the complete driveshaft. For lubrication of journal cross assemblies, see Installation and Maintenance/Safety Instructions.

* The dimensions of the journal cross assemblies for series 392/393 are equal to 292.

Shaft size	$\varnothing A$ mm	B mm
473.10	15	41
473.20	19	49,2
473.30	22	59
287.00	26	69,8
287.10	30	81,8
287.20	35	96,8
587.10	35	96,8
587.15	42	104,5
587.20	48	116,5
587.30	52	133
587.35/36	57	144
587.42	57	152,06
587.48	65	172
587.50	72	185
587.55	74	217
587.60	83	231,4
687/688.15	27,0	74,5
687/688.20	30,2	81,8
687/688.25	34,9	92,0
687/688.30	34,9	106,4
687/688.35	42,0	119,4
687/688.40	47,6	135,17
687/688.45	52,0	147,2
687/688.55	57,0	152,0
687/688.65	65,0	172,0

Shaft size	$\varnothing A$ mm	B mm	B ₁ mm
190.50	65	220	143
190.55	74	244	154
190.60	83	280	175
190.65	95	308	190
190.70	110	340	210
190.75	120	379	235
190.80	130	425	262
390.60	83	235,8	129
390.65	95	258,8	139
390.70	110	293,4	160
390.75	120	325,2	176
390.80	130	363,2	196
392.50*	74	222	129
392.55*	83	246	139
392.60*	95	279,6	160
392.65*	110	309,6	176
392.70*	120	343,4	196
393.75*	130	383,4	216
393.80*	154	430	250
393.85*	170	464	276
393.90*	195	530	315

Ultra heavy-duty unit pack sets for series 398 have been discontinued.

They are still available for series 492 and 498 on request.

Data sheet Flange connection with serration

Hirth-serration

- Flank angle 40°
- High transmission capacity
- Form locking
- Self-centering

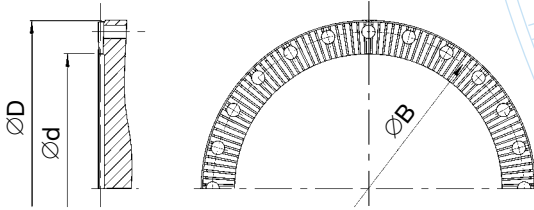

D mm	d mm	z	B mm	i*
225	180	48	200	8 x M 12
250	200	48	225	8 x M 14
285	225	60	255	10 x M 14
315	250	60	280	10 x M 16
350	280	72	315	12 x M 16
390	315	72	350	12 x M 18
435	345	96	395	16 x M 18
480	370	96	445	16 x M 20
550	440	96	510	16 x M 22
600	480	120	555	20 x M 24
650	520	120	605	20 x M 24
700	570	120	655	24 x M 24
750	600	144	695	24 x M 30
800	650	144	745	24 x M 30
850	680	144	785	24 x M 36
900	710	144	835	24 x M 36
950	760	144	885	24 x M 36
1.000	800	180	925	20 x M 42 x 3
1.050	840	180	975	20 x M 42 x 3
1.100	880	180	1.025	20 x M 42 x 3
1.150	925	180	1.065	20 x M 48 x 3
1.200	960	180	1.115	20 x M 48 x 3

Klingenberg-serration

- Flank angle 25°
- High transmission capacity
- Form locking
- Self-centering

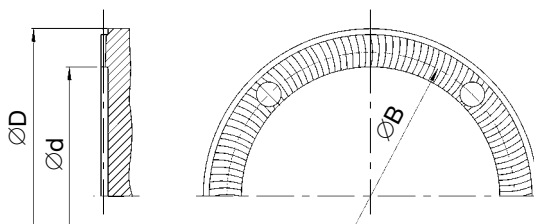

D mm	d mm	z	B mm	i
95	65	16	84	4 x M 8
115	80	24	101,5	4 x M 10
145	110	24	130	4 x M 12
175	140	32	155,5	4 x M 16
215	175	48	196	4 x M 16
240	195	48	218	4 x M 18
275	220	48	245	4 x M 20
305	245	48	280	4 x M 20
340	280	72	310	4 x M 22
380	315	72	345	6 x M 24
425	355	96	385	6 x M 27
465	390	96	425	8 x M 30
535	455	96	492	8 x M 30

D = Outside diameter
d = Inside diameter
Z = Number of teeth
B = Pitch diameter
i = Number and size of bolts
Bolt material: 10.9

* Reduced number of bolts by special arrangement only (e.g., for use as quick-change system)

Other diameters available on request.

Data sheet Face key connection series 687/688/587/390

The driveshaft for series 687/688/587/390 can also be manufactured with face key connection on request.

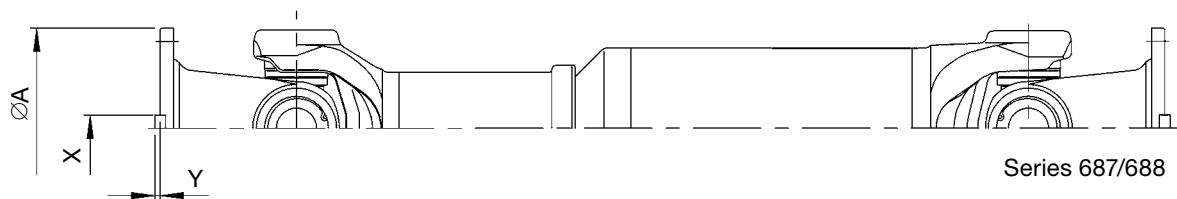

Series 687/688

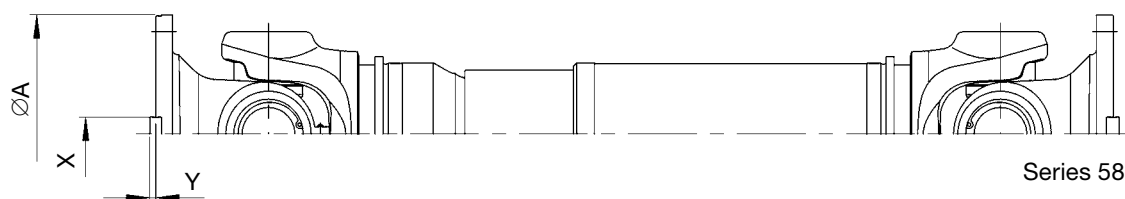

Series 587

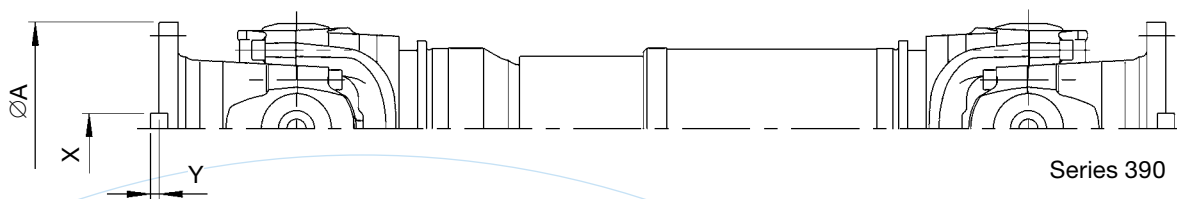

Series 390

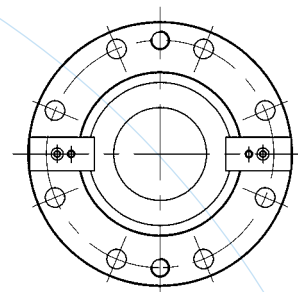

Driveshaft connection				
Shaft size	$\varnothing A$ mm	$(I^2) \times H^1)$	X e9 mm	Y mm
687/688.35	150	8 x 13	20	4,0
687/688.40				
687/688.45	180	8 x 15	25	4,5
687/688.55		10 x 17		
687/688.65		10 x 17		
587.50	225	8 x 17	32	5,5
587.55	250	8 x 19	40	7,0
587.60	285	8 x 21	45	8,0
390.60	285	8 x 21	45	8,0
390.65	315	8 x 23	45	8,0
390.70	350	10 x 23	50	9,0
390.75	390	10 x 25	50	9,0
390.80	435	10 x 28	63	12,0

1. Tolerance + 0,2 mm
(for 390.75 and 390.80,
tolerance + 0,5 mm)

2. Number of flange holes

Data sheet standard companion flanges

Standard companion flanges can be manufactured with cylindrical bore holes and face keyway (material C45; hardened and tempered 750 – 900 N/mm²) on request. For designs

deviating from the standard, e.g., oil pressure connection, conical bore, flat journal, and material, relevant drawings are required.

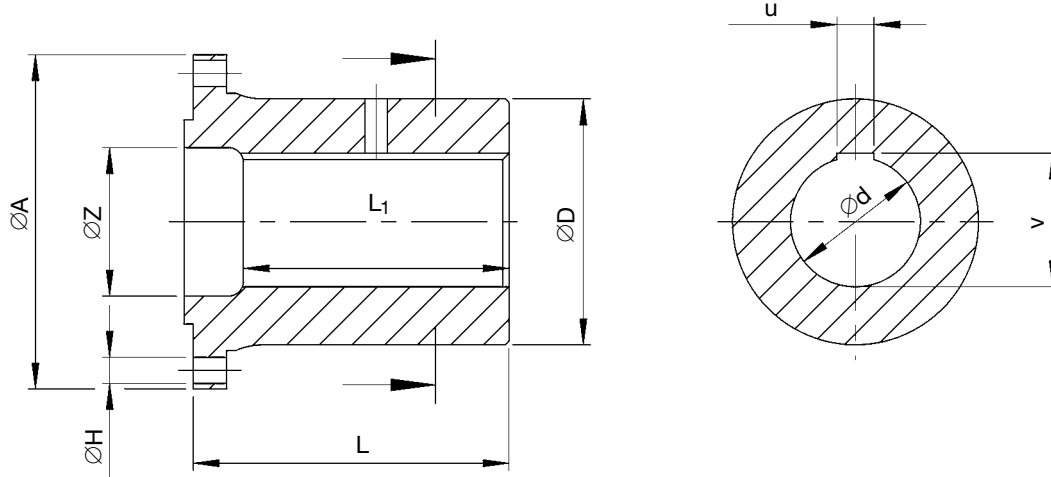

Please state with your order:

- Shaft size = _____
- Flange dia. A = _____ mm
- I x H = __ number of holes x Ø __ mm
- L = _____ mm
- L₁ = _____ mm
- Z = _____ mm
- D = _____ mm
- d = _____ mm
- u = _____ mm
- v = _____ mm

Driveshaft connection			Dimension
Shaft size	Ø A mm	I ² x H ¹)	Ø D _{max} mm
687/688.15 687/688.20	100	6 x 8,25	69,5
687/688.15 687/688.20 687/688.25 687/688.30	120	8 x 10,25	84
687/688.25 687/688.30	150	8 x 12,25	110,3
687/688.35 687/688.40		8 x 12,25	
687/688.35 687/688.40 687/688.45		8 x 12,1	
687/688.55 687/688.65	180	8 x 14,1	132,5
687/688.45 687/688.55 687/688.65		10 x 16,1	
687/688.45 687/688.55 687/688.65	225	8 x 16,1	171
587.50 587.50 587.55	250	8 x 18,1	189
587.60 390.60			
390.65 390.70	285	8 x 20,1	213
390.75 390.80	315	8 x 22,1	247
	350	10 x 22,1	277
	390	10 x 24,1	308
	435	10 x 27,1	342

1. Tolerance + 0,2 mm
(for 390.75 and 390.80,
tolerance + 0,5 mm)

2. Number of flange holes

Design features series 687/688/587

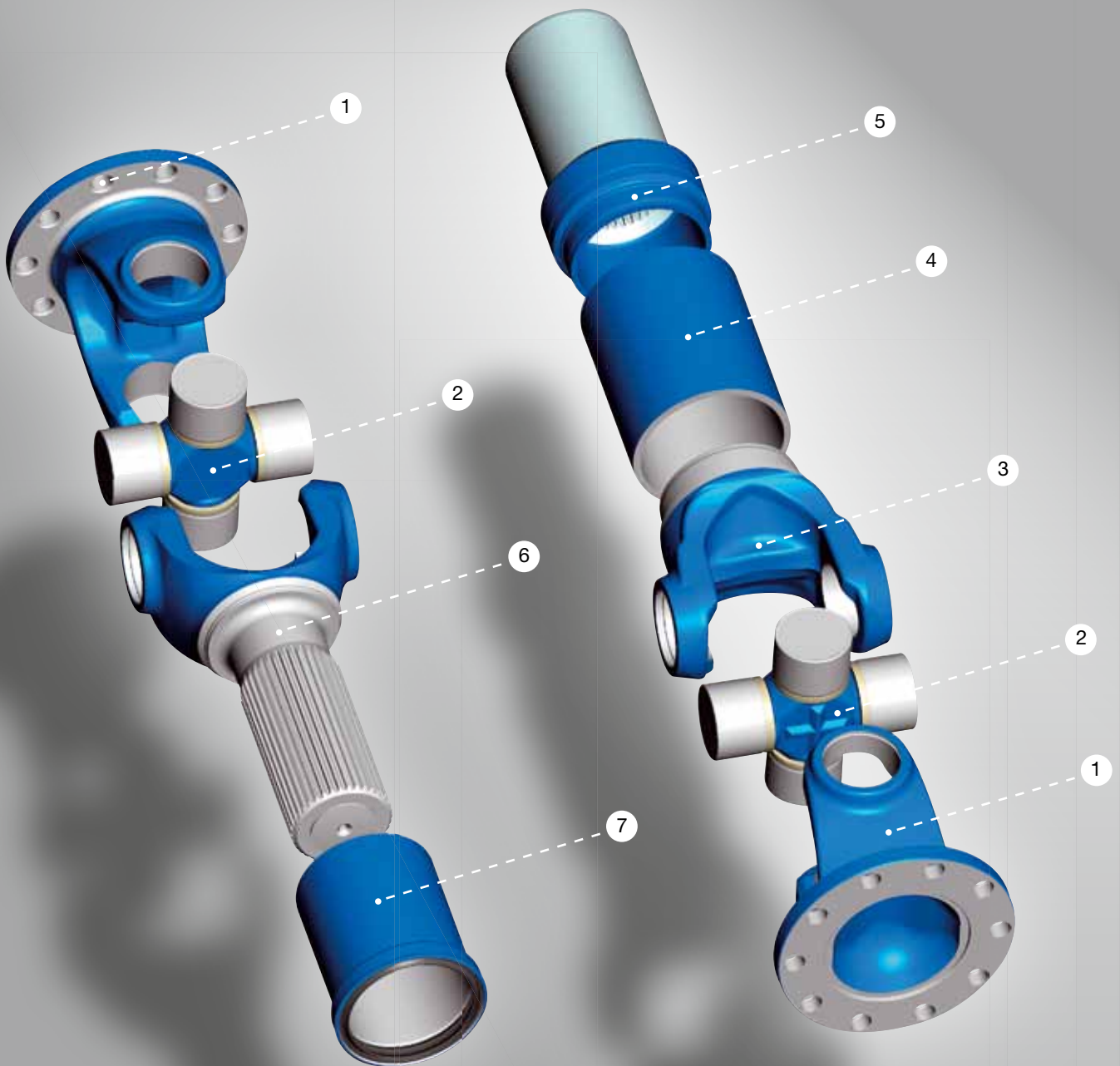

Main components of the driveshafts

1. Flange yoke
2. Journal cross assembly
3. Tube yoke
4. Tube
5. Sliding muff
6. Yoke shaft
7. Cover tube assembly

Design features series 390/392/393

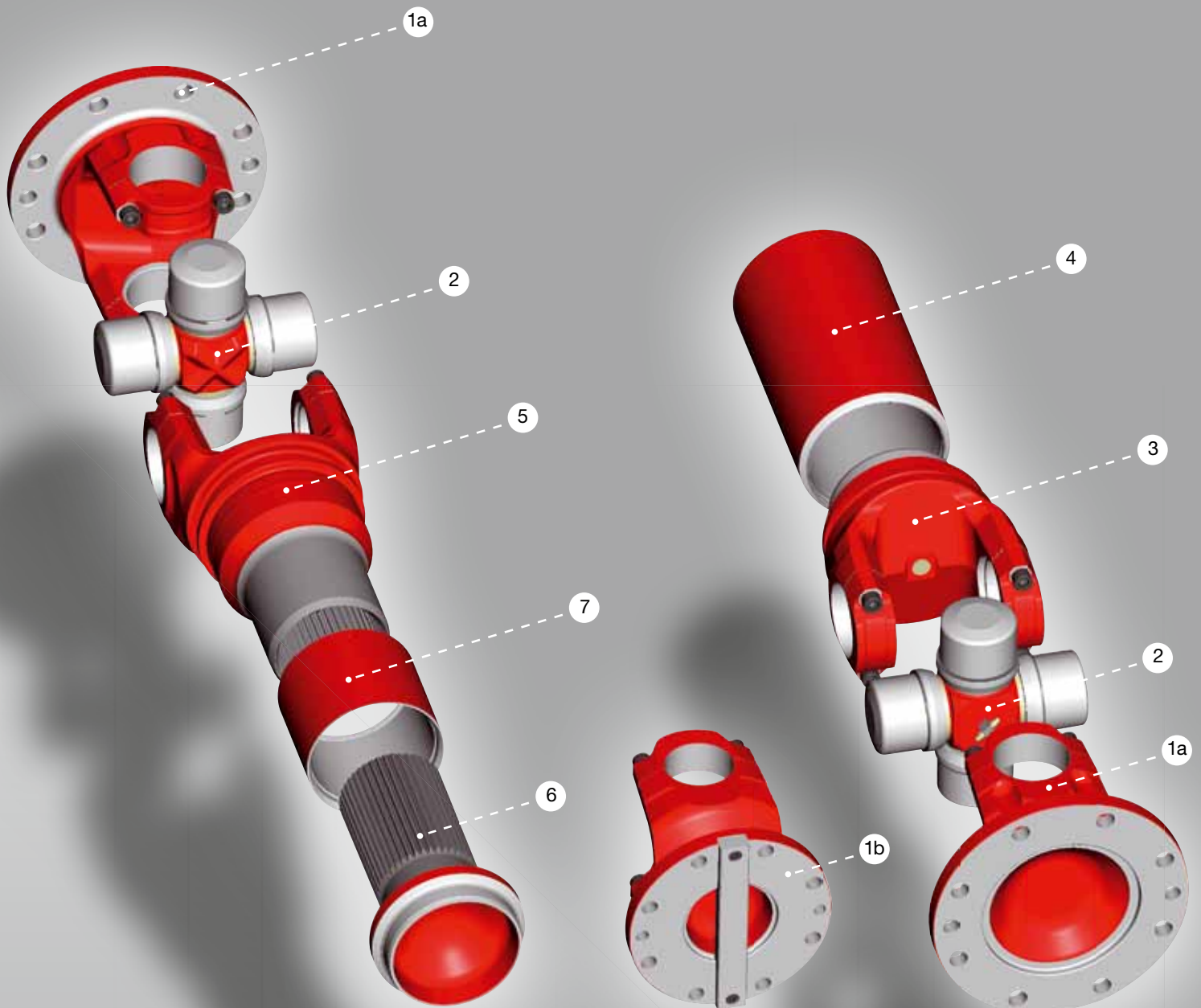

Main components of the driveshafts

- 1a. Flange yoke for series 390
(friction connection)
- 1b. Flange yoke for series 392/393
(face key connection)
- 2. Journal cross assembly
- 3. Tube yoke
- 4. Tube
- 5. Tube yoke with sliding muff
- 6. Slip stub shaft
- 7. Cover tube assembly

General theoretical instructions

Kinematics of Hooke's joints

1. The joints

In the theory of mechanics, the cardan joint (or Hooke's joint) is defined as a spatial or spherical drive unit with a non-uniform gear ratio or transmission. The transmission behavior of this joint is described by the following equation:

$$\alpha_2 = \arctan\left(\frac{1}{\cos\beta} \cdot \tan\alpha_1\right)$$

β = Deflection angle of joint [°]
 α_1 = angle of rotation drive side
 α_2 = angle of rotation driven side

In this equation, α_2 is the momentary rotation angle of the driven shaft 2. The motion behavior of the driving and the driven ends is shown in the following diagram. The asynchronous and/or non-

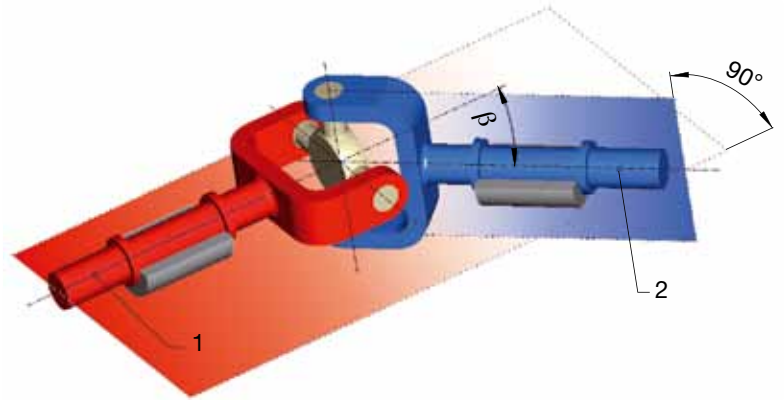

homokinematic running of the shaft 2 is shown in the periodical oscillation of the asynchronous line α_2 around the synchronous line α_1 (dotted line).

A measure for the non-uniformity is the difference of the rotation angles α_2 and α_1 or the transmission ratio of the angular speeds ω_2 and ω_1 . Expressed by an equation, that means:

a) Rotation angle difference:

$$\varphi_K = \alpha_2 - \alpha_1$$

(also called gimbal error)

$$\varphi_K = \arctan\left(\frac{1}{\cos\beta} \cdot \tan\alpha_1\right) - \alpha_1$$

$$\varphi_{K \max.} = \arctan\left(\frac{\cos\beta - 1}{2\sqrt{\cos\beta}}\right)$$

b) Ratio:

$$i = \frac{\omega_2}{\omega_1} = \frac{\cos\beta}{1 - \sin^2\beta \cdot \cos^2\alpha_1}$$

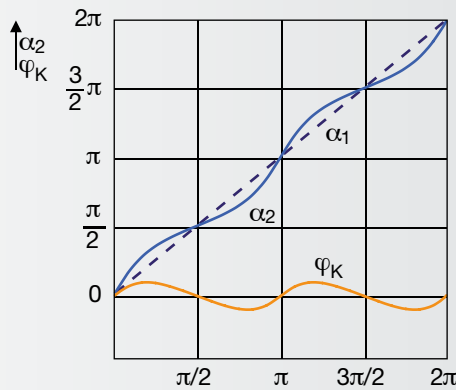

General theoretical instructions

The following diagram shows the ratio $i = \omega_2/\omega_1$ for a full revolution of the universal joint for $\beta = 60^\circ$.

The degree of non-uniformity U is defined by:

$$U = i_{\max.} - i_{\min.} = \tan\beta \cdot \sin\beta$$

Where:

$$i_{\max.} = \frac{1}{\cos\beta}$$

$$i_{\min.} = \cos\beta$$

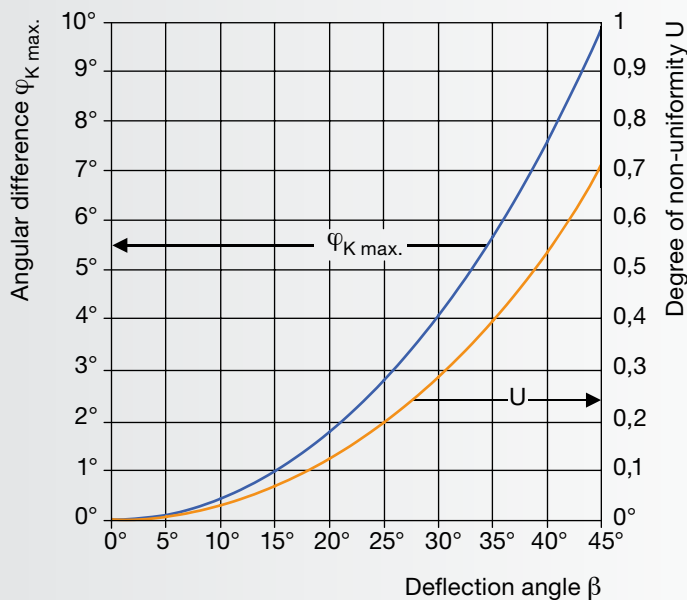
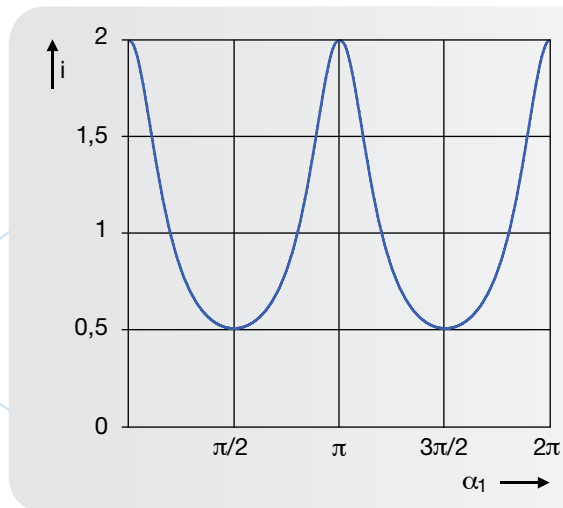

The diagram shows the course of the degree of non-uniformity U and of the angular difference $\varphi_{K \max.}$ as a function of the deflection angle of the joint from 0 to 45° .

From the motion equation it is evident that a homokinematic motion behavior corresponding to the dotted line under 45° – as shown in the diagram – can only be obtained for the deflection angle $\beta = 0^\circ$. A synchronous or homokinematic running can be achieved by a suitable combination or connection of two or more joints.



Technical instructions for application

2. The driveshaft

The rotation angle difference φ_K or the gimbal error of a deflected universal joint can be offset under certain installation conditions

with a second universal joint.

1. The deflection angles of both joints must be equal (i.e., $\beta_1 = \beta_2$)

The constructive solutions are the following:

Two arrangements are possible:

1a) Z-deflection

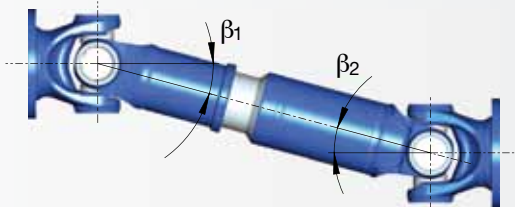

1b) W- or M-deflection

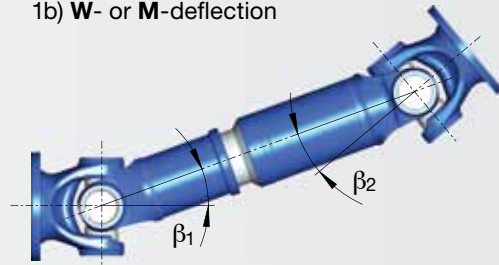

2. The two joints must have a kinematic angular relationship of 90° ($\pi/2$), (i.e., the yokes of the connecting shaft are in one plane).

For a more intensive study of universal shaft kinematics, please refer to the VDI-recommendation 2722 and to the relevant technical literature.

Operating angles

The most common arrangements are the Z- and W-deflections. To begin, consider the system in which the shafts to be connected are in the same plane.

Z-arrangement

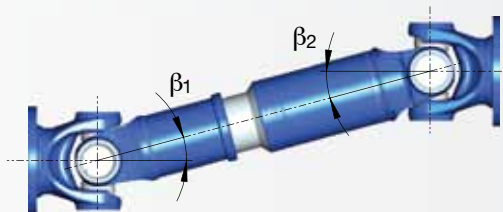

W-arrangement

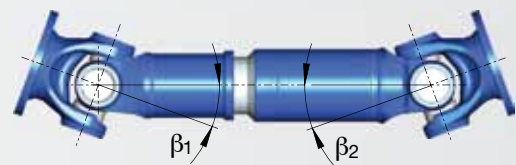

Maximum permissible angle difference

The condition $\beta_1 = \beta_2$ is one of the essential requirements for a uniform output speed condition

and cannot always be fulfilled. Therefore, designers and engineers will often ask for the permissible difference between the deflection angles of both joints.

The deflection angles for high-torque and high-speed machine drives should be equal. If not, the difference should be limited to 1° to $1,5^\circ$.

Technical instructions for application

Product of speed and deflection angle

Greater differences of about 3° to 5° are acceptable without disadvantages in low-speed applications. For applications with varying deflection conditions, it is important to obtain uniformity, if possible over the complete deflection range.

Deflection in two planes means that the deflection is both horizontal and vertical. The combination of two identical types of deflection (Z/Z or W/W) and identical deflection angles ensure uniformity. For a combination of Z- and W-deflection, the inner yokes must be offset. Please consult with Dana application engineers to determine the proper amount of angular offset.

Determination of the maximum permissible operating deflection angle β

Depending on the driveshaft series, the maximum deflection angle per joint is $\beta = 5^\circ$ to 44° . Due to the kinematic conditions of the cardan joint, as described before, the deflection angle must be limited in relation to the speed.

Calculations and observations of many applications have shown that certain mass acceleration torques of the center part must not be exceeded in order to guarantee smooth running of the drive systems. This acceleration torque depends on the

$$D = n \cdot \beta$$

and the moment of inertia of the middle part of the shaft. The parameter D is proportional to the angular acceleration of the driveshaft center part \mathcal{E}_2 .

$$\mathcal{E}_2 \sim D = n \cdot \beta$$

n = Operating speed [rpm]
 β = Deflection angle of joint [β°]
 \mathcal{E}_2 = Angular acceleration of driveshaft center part

The maximum permissible deflection angle at a given speed and an average driveshaft length can be determined from the following diagram.

For an exact determination, contact Dana.



Technical instructions for application

Limits for the product of operating speed and deflection angle

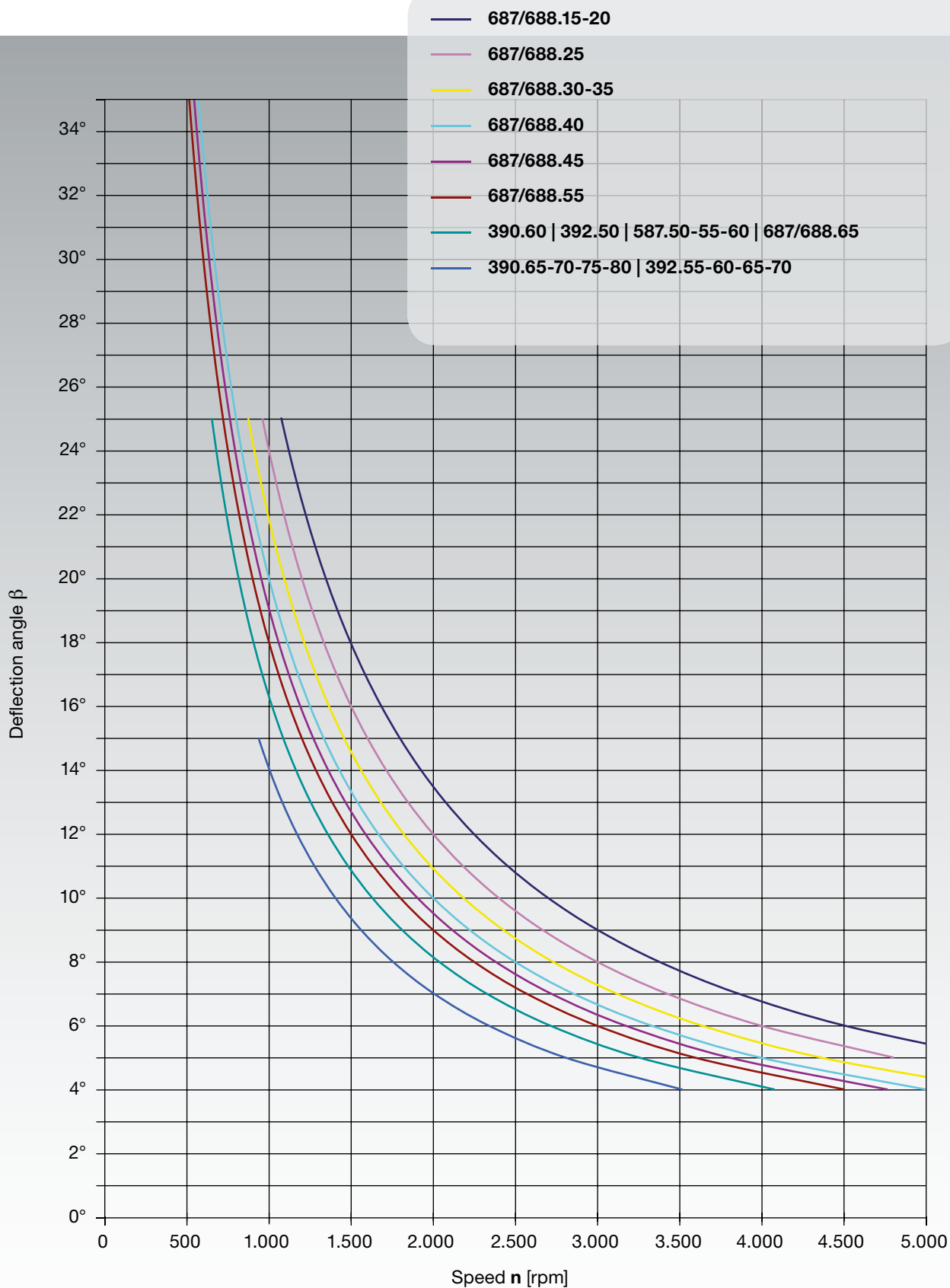

Technical instructions for application

Speed

Checking the critical torsional speed

The plant or vehicle manufacturer has to prevent the use of driveshafts within the critical torsional speed ranges of the drive.

Therefore, the determination of the critical torsional speed ranges of the drive system is required.

The values for the moment of inertia and torsional stiffness of the selected driveshaft can be taken from the data sheets or be supplied upon request.

Checking the critical bending speed

Except for short and rigid designs, driveshafts are flexible units with critical bending speeds and flexural vibrations that have to be checked. To accomplish this, the first and possibly second order critical bending speeds are important.

For safety reasons, the maximum permissible operating speed must be at a sufficient distance from the critical bending speed.

$$n_{\text{perm. max.}} \approx 0,8 \cdot n_{\text{crit.}} [\text{rpm}]$$

The critical bending speed for a particular shaft size is determined by the length and the tube diameter only (see diagram). For greater length dimensions, the tube diameter has to be increased.

The diameter is limited because of the ratio to the shaft size.

Therefore, single driveshafts can only be provided up to a certain length. All installations exceeding this limit have to be equipped with subdivided drive lines.

For determination of the critical bending speed, see the following selection diagrams.

These diagrams only apply to driveshafts that are installed with solid bearing supports located close to the flange.

Different installations (e.g., units with elastic mounting bearing) must have lower critical bending speeds.

Depending on the type of the plant, excitations of second order can cause flexible vibrations. Please contact Dana engineers if the deflection angle exceeds 3° and for greater length dimensions.



Technical instructions for application

Series 687/688

Determination of the critical bending speed depending on the respective operating length

- 687/688.15 - 63,5 x 2,4
- 687/688.20 - 76,2 x 2,4
- 687/688.25 - 89 x 2,4
687/688.30 - 90 x 3
- 687/688.35 - 100 x 3
- 687/688.40 - 100 x 4,5
- 687/688.40 - 120 x 3
687/688.45 - 120 x 4
687/688.55 - 120 x 6
- 687/688.45 - 110 x 5
- 687/688.65 - 142 x 6

Example: 687.15 – 63,5 x 2,4
 Joint size 687.15
 Tube outer diameter 63,5 mm
 Wall thickness 2,4 mm

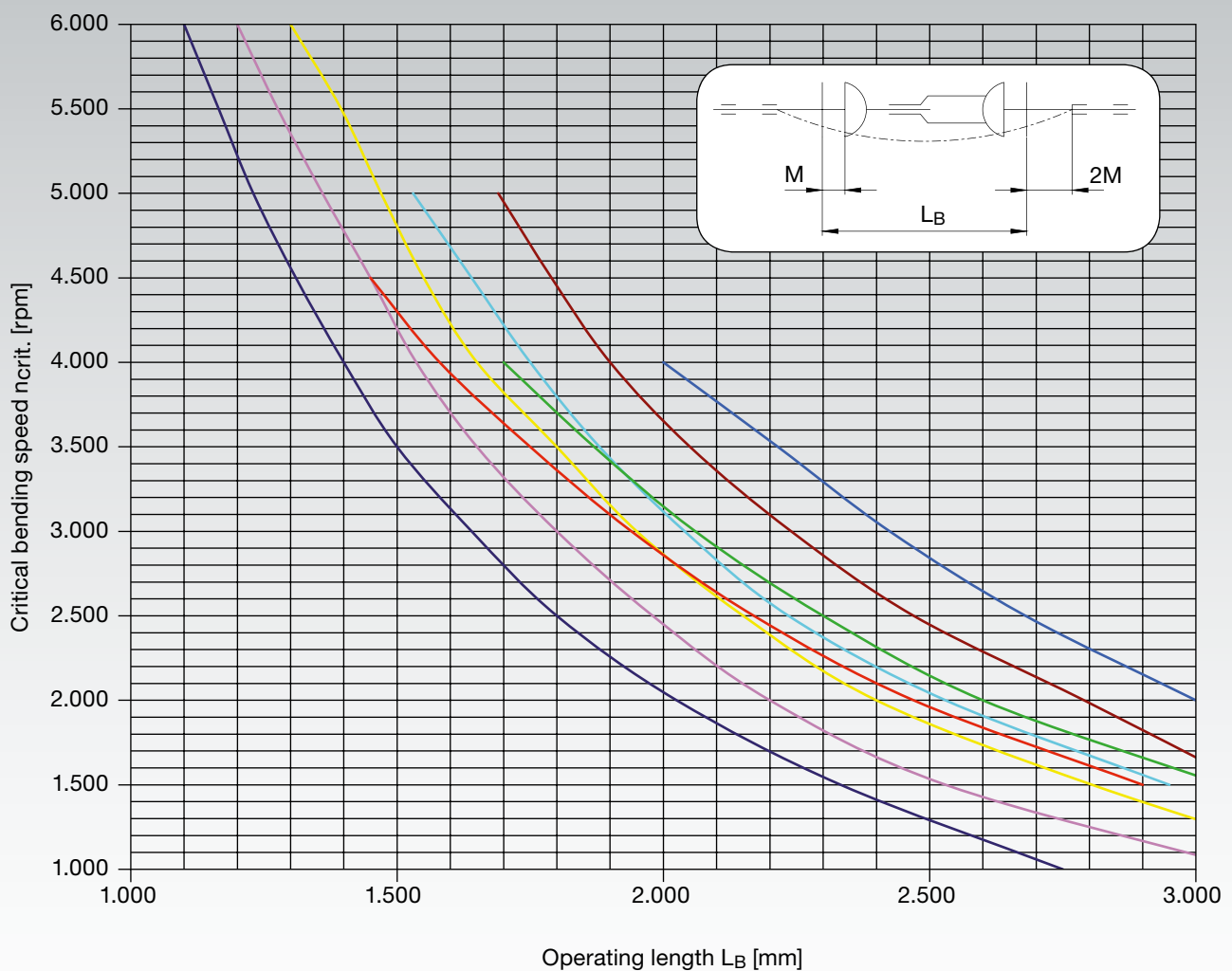

Technical instructions for application

Series 587/390/392

Determination of the critical bending speed depending on the respective operating length

- 587.50 - 144 x 7
- 587.55 - 168,8 x 7,3
587.60/392.50/390.60 - 167,7 x 9,8
- 392.55/390.65 - 218,2 x 8,7
- 392.60/390.70 - 219 x 13,3
- 392.65/390.75 - 273 x 11,6
- 392.70/390.80 - 273 x 19

Example: 390.60 – 167,7 x 9,8
 Joint size 390.60
 Tube outer diameter 167,7 mm
 Wall thickness 9,8 mm

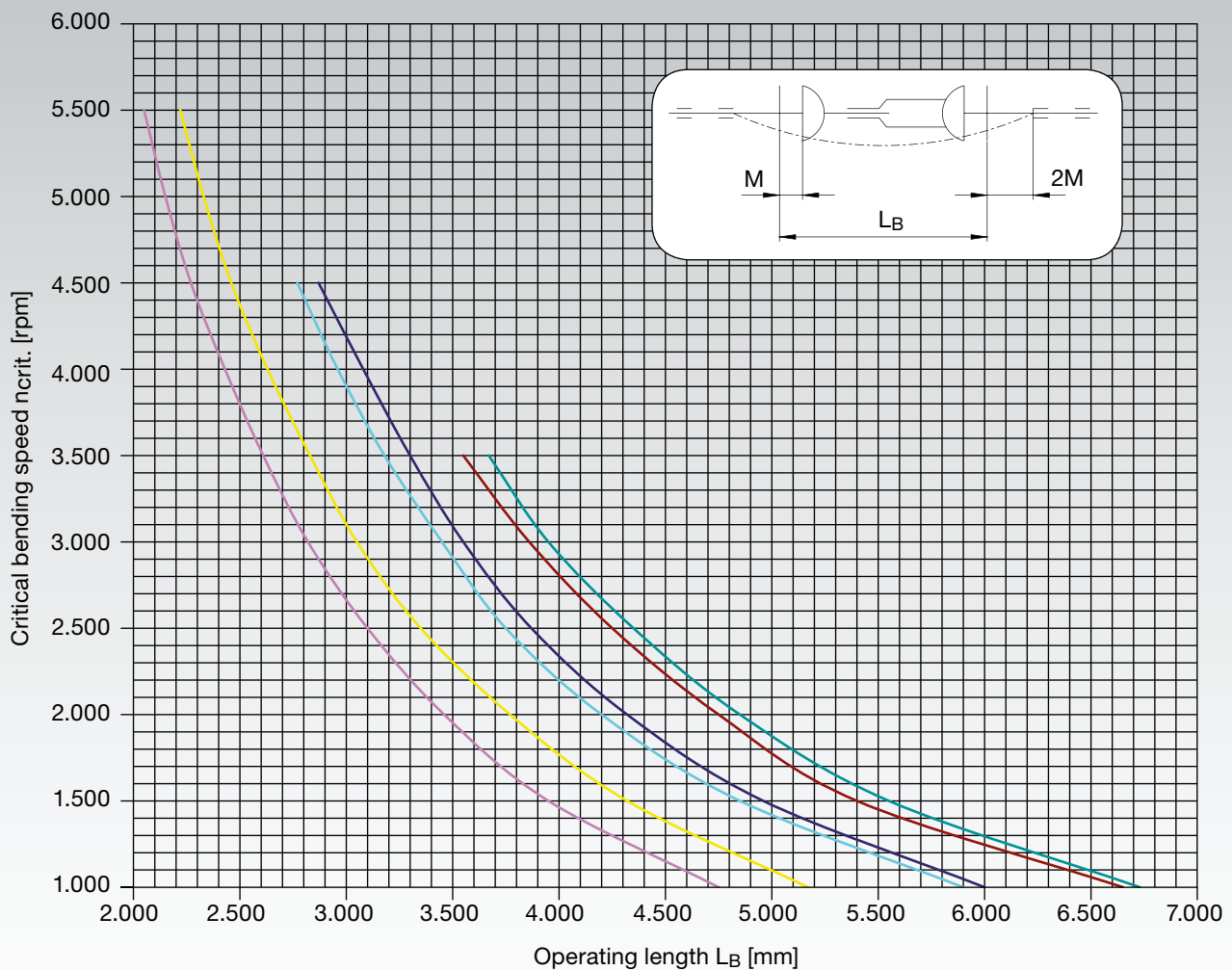

Technical instructions for application

Length dimensions

The operating length of a driveshaft is determined by:

- the distance between the driving and the driven units
- the length compensation during operation

The following abbreviations are used:

L_z = Compressed length

This is the shortest length of the shaft. A further compression is not possible.

L_a = Length compensation

The driveshaft can be expanded by this amount. An expansion beyond that dimension is not permissible.

$L_z + L_a$ = **Maximum permissible operating length L_{Bmax} .**

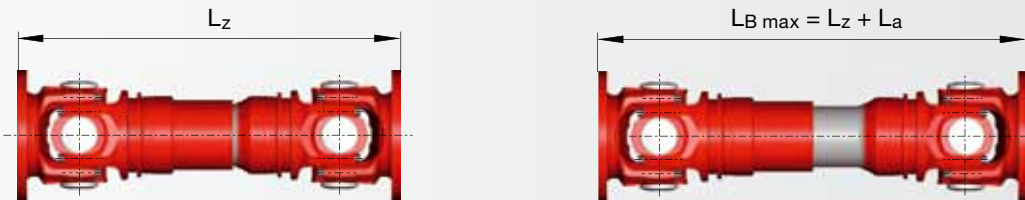

During operation, the driveshaft can be expanded up to this length. The optimum working length L_B of a driveshaft is achieved if the length compensation is extracted by one-third of its length.

$$L_B = L_z + \frac{1}{3}L_a \quad [\text{mm}]$$

This general rule applies to most of the arrangements. For applications where larger length alterations are expected, the operating

length should be chosen in such a way that the movement will be within the limit of the permissible length compensation.

Arrangements of driveshafts

A tandem arrangement of driveshafts could become necessary to cope with greater installation lengths.

Basic forms of shaft combinations:

Driveshaft with intermediate shaft



Driveshaft with two intermediate shafts

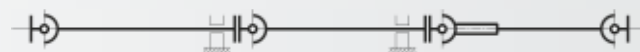

Two driveshafts with double intermediate bearing



Technical instructions for application

In such arrangements, the individual yoke positions and deflection angles should be adjusted with regard to one another in such a way that the degree of non-uniformity (see General theoretical instructions) and the reaction forces acting on the connection bearings (see Technical instructions for application) are minimized.

Load on bearings of the connected units

Axial forces

For the design of a driveshaft, it must be taken into account that axial forces can occur. These forces must be absorbed by axial thrust bearings of the connected units.

Axial forces will occur during length variations in the driveshaft. Additional axial forces are caused by increasing torque and by increasing pressure during lubrication of the splines. These forces will decrease automatically and can be accelerated by the installation of a relief valve.

The axial force A_k is a combination of two components:

1. Frictional force F_{RL}

This is the force that occurs in the length compensation. It can be determined from:

$$F_{RL} = T \cdot \frac{\mu}{r_m} \cdot \cos \beta$$

F_{RL} = Frictional force from the length compensation [N]

It depends on:

T = Torque of the driveshaft [Nm]

r_m = Pitch circle radius in the sliding parts of the driveshaft [m]

μ = Friction coefficient (depends on spline treatment):

- 0,08 for plastic-coated splines
- 0,11 for steel/steel (greased)

β = Operating deflection angle

2. Power F_p

This force occurs in the length compensation due to the increasing pressure in the lubrication grooves of the driveshaft.

The force depends on the lubrication pressure (maximum permissible pressure is 15 bar).

Dana's environmental protection management policy

An important feature of Dana's environmental protection management policy is dedication to product responsibility. Because of this commitment, the effect of driveshafts on the environment is given considerable attention. **GWB™** driveshafts are lubricated with lead-free grease, their paint finishes are low in solvents and free of heavy metals, and they are easy to maintain. After use, they can be introduced into the recycling process.

Technical instructions for application

Calculation scheme of radial forces on connecting bearings

Driveshaft in Z-arrangement

Position 0° , flange yoke right-angled to drawing plane, Position $\pi/2$, flange yoke in drawing plane

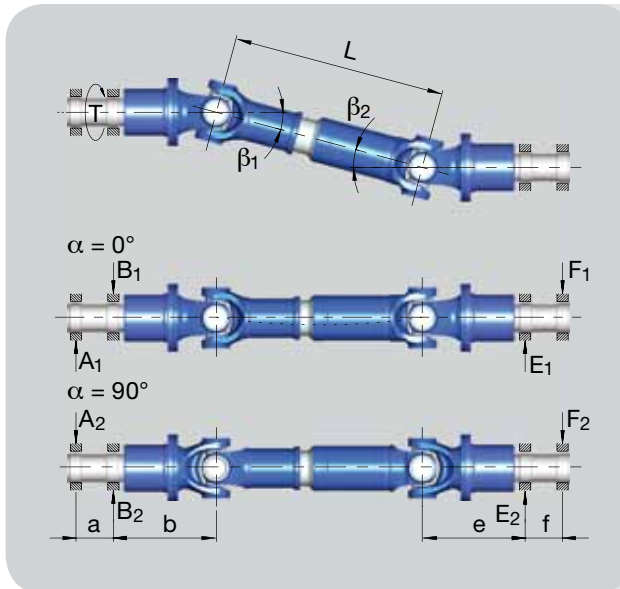

Driveshaft in W-arrangement

Position 0° , flange yoke right-angled to drawing plane, Position $\pi/2$, flange yoke in drawing plane

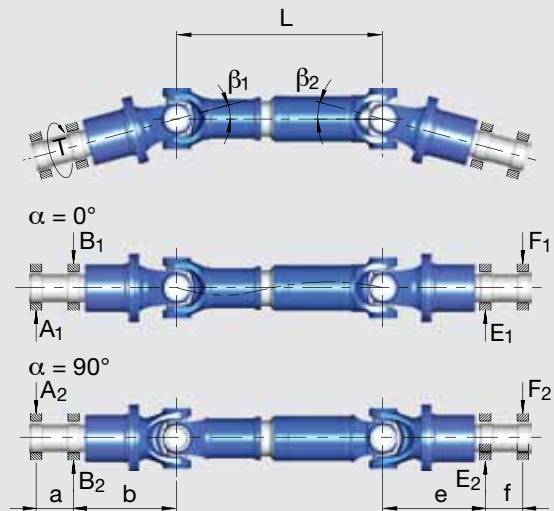

$$\alpha = 0^\circ \quad A_1 = T \cdot \frac{\cos\beta_1 \cdot b}{L \cdot a} \cdot (\tan\beta_1 - \tan\beta_2)$$

$$B_1 = T \cdot \frac{\cos\beta_1 \cdot (a + b)}{L \cdot a} \cdot (\tan\beta_1 - \tan\beta_2)$$

$$F_1 = T \cdot \frac{\cos\beta_1 \cdot e}{L \cdot f} \cdot (\tan\beta_1 - \tan\beta_2)$$

$$E_1 = T \cdot \frac{\cos\beta_1 \cdot (e + f)}{L \cdot f} \cdot (\tan\beta_1 - \tan\beta_2)$$

$$\alpha = \pi/2 = 90^\circ \quad A_2 = B_2 = T \cdot \frac{\tan\beta_1}{a}$$

$$F_2 = E_2 = T \cdot \frac{\sin\beta_2}{f \cdot \cos\beta_1}$$

$$\alpha = 0^\circ \quad A_1 = T \cdot \frac{\cos\beta_1 \cdot b}{L \cdot a} \cdot (\tan\beta_1 + \tan\beta_2)$$

$$B_1 = T \cdot \frac{\cos\beta_1 \cdot (a + b)}{L \cdot a} \cdot (\tan\beta_1 + \tan\beta_2)$$

$$F_1 = T \cdot \frac{\cos\beta_1 \cdot e}{L \cdot f} \cdot (\tan\beta_1 + \tan\beta_2)$$

$$E_1 = T \cdot \frac{\cos\beta_1 \cdot (e + f)}{L \cdot f} \cdot (\tan\beta_1 + \tan\beta_2)$$

$$\alpha = \pi/2 = 90^\circ \quad A_2 = B_2 = T \cdot \frac{\tan\beta_1}{a}$$

$$F_2 = E_2 = T \cdot \frac{\sin\beta_2}{f \cdot \cos\beta_1}$$

Driveshaft arrangement with equal deflection angles and equal bearing distances

$$\beta_1 = \beta_2$$

$$a = f, b = e$$

$$\alpha = 0^\circ \quad A_1 = F_1 = B_1 = E_1 = 0$$

$$\alpha = \pi/2 = 90^\circ \quad A_2 = B_2 = T \cdot \frac{\tan\beta_1}{a}$$

$$F_2 = E_2 = T \cdot \frac{\tan\beta_1}{a}$$

Driveshaft arrangement with equal deflection angles and equal bearing distances

$$\beta_1 = \beta_2$$

$$a = f, b = e$$

$$\alpha = 0^\circ \quad A_1 = F_1 = 2T \cdot \frac{\sin\beta_1 \cdot b}{L \cdot a}$$

$$B_1 = E_1 = 2T \cdot \frac{\sin\beta_1 \cdot (a + b)}{L \cdot a}$$

$$\alpha = \pi/2 = 90^\circ \quad \text{See Z-arrangement } \alpha = \pi/2$$

Technical instructions for application

Balancing of driveshafts

The balancing of driveshafts is performed to equalize eccentrically running masses, therefore preventing vibrations and reducing the load on any connected equipment.

Balancing is carried out in accordance with ISO Standard 1940, "Balance quality of rotating rigid bodies". According to this standard, the permissible residual unbalance is dependent on the operating speed and mass of the balanced components.

Dana's experience has shown that balancing is not normally required for rotational speeds below 500 rpm. In individual cases, this range may be exten-

ded or reduced, depending on the overall drivetrain characteristics.

Driveshafts are balanced in two planes, normally to a balancing accuracy between G16 and G40.

- **Balancing speed**

The balancing speed is normally the maximum speed of the system or vehicle.

- **Quality grade**

In defining a quality grade, it is necessary to consider the reproducibility levels achievable in the customer's own test rig during verification testing. Quality grades are dependent on the following variables:

- Type of balancing machine (hard, rigid or soft suspension)
- Accuracy of the measuring system
- Mounting tolerances
- Joint bearing radial and axial play
- Angular backlash in longitudinal displacement direction

Field analyses have shown that the sum of these factors may result in inaccuracies of up to 100 %. This observation has given rise to the definition of the following balancing quality grades:

- Producer balancing: G16
- Customer verification tests: G32

G 40	Car wheels, wheel rims, wheel sets, driveshafts Crankshaft/drives of elastically mounted, fast four-cycle Engines (gasoline or diesel) with six or more cylinders Crankshaft/drives of engines of cars, trucks, and locomotives
G 16	Driveshafts (propeller shafts, cardan shafts) with special requirements Parts of crushing machines and agricultural machinery Individual components of engines (gasoline or diesel) for cars, trucks, and locomotives Crankshaft/drives of engines with six or more cylinders under special requirements
G 6,3	Parts of process plant machines Marine main turbine gears (merchant service) Fans, flywheels, centrifuge drums Paper machinery rolls, print rolls Assembled aircraft gas turbine rotors Pump impellers
G 2,5	Gas and steam turbines, including marine main turbines (merchant service) Rigid turbo-generator rotors Turbo-compressors, turbine-driven pumps Machine tool drives Computer memory drums and discs

Extract from DIN ISO 1940/Part 1

Selection of GWB™ driveshafts

The design of driveshafts must exclude all possible danger to people and material by secured calculation and test results, as well as other suitable steps (see Installation and Maintenance/Safety Instructions).

The selection procedure described on these pages is only a general recommendation. Please consult Dana engineers for the final design for your application.

The selection of a driveshaft should be based on the following conditions:

1. Specifications of driveshafts
2. Selection by bearing life
3. Operational dependability
4. Operating angles
5. Speed
6. Length dimensions
7. Load on bearings of the connected units

1. Specifications of driveshafts

T_{CS} = Functional limit torque [Nm]

Up to this maximum permissible torque, a load may be applied to a driveshaft for a limited frequency without the working capability being affected by permanent deformation of any driveshaft functional area. This does not result in any unpermissible effect on bearing life.

Yield torque

This torque level leads to irreversible plastic deformation of the driveshaft which could result in a failure of the complete drive system.

T_{DW} = Reversing fatigue torque [Nm]

At this torque, the driveshaft is permanently solid at alternating loads. The values for driveshafts of series 687/688 with welded balancing plates are lower. With a fatigue torque of this order, the transmission capacity of the flange connection must be checked.

T_{DSch} = Pulsating fatigue torque [Nm]

At this torque, the driveshaft is permanently solid at pulsating loads.

$$T_{DSch} = 1,4 \cdot T_{DW}$$

L_C = Bearing capacity factor

The bearing capacity factor takes into consideration the dynamic service life C_{dyn} (see DIN/ISO 281) of the bearings and the joint geometry R. The L_C values for the different shaft sizes are shown in the tables (see data sheets).

When selecting driveshafts, the bearing life and the operating strength must be considered separately. According to the load state, the reversing fatigue torque T_{DW} or the pulsating fatigue torque T_{DSch} must also be taken into consideration.

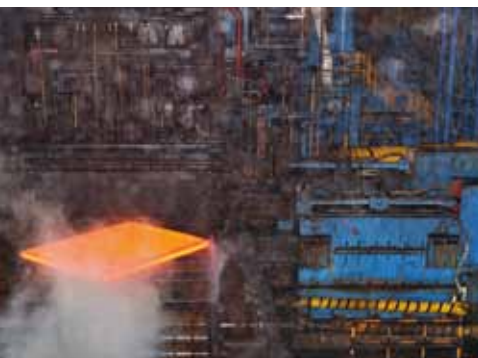

Selection of GWB™ driveshafts

2. Selection by bearing life

By bearing capacity factor L_C

The bearing life L_h of a driveshaft depends on the bearing capacity factor and is based on the following formula:

$$L_h = \frac{L_C \cdot 10^{10}}{n \cdot \beta \cdot T^{10/3} \cdot K_1}$$

If the desired bearing life L_h is given, the joint size can be calculated by the bearing capacity factor L_C .

$$L_C = \frac{L_h \cdot n \cdot \beta \cdot T^{10/3} \cdot K_1}{10^{10}}$$

The L_C values can be taken from the tables (see data sheets).

L_C = Bearing capacity factor

n = Operating speed [rpm]

β = Operating deflection angle [$^\circ$]

T = Operating torque [kNm]

K_1 = Shock factor

If operating data are based on a duty cycle, a more precise durability can be calculated.

Drives with internal combustion engines may cause torque peaks that must be considered by factor K_1 .

Electric motor/turbine $K_1 = 1,00$

Gasoline engine

4 cylinder and more $K_1 = 1,15$

Diesel engine

4 cylinder and more $K_1 = 1,20$

The values shown in the tables are general values. If a flexible coupling is used, the shock factor is lower. Principally the data of the motor and/or coupling manufacturer must be observed.

3. Operating dependability

The operating dependability can be determined if a certain duty cycle is given. The calculated service life of a driveshaft under normal working conditions has to achieve or exceed the required service life.

Duty cycles are often not available. In such cases, Dana engineers will make use for almost

70 years of experience as a manufacturer of driveshafts to provide an optimal selection.

Calculations are based on the peak torque T and the maximum peak torque T_{SP} that may occur. The peak torque is determined according to the type of operation and the torque characteristic. It should be lower than the corresponding torques T_{DSch} and T_{DW} .

$$T_N \cdot K = T < T_{DSch} \text{ or } T_{DW}$$



Selection of **GWB™** drivshafts

Typical types of torques:

Pulsating stress

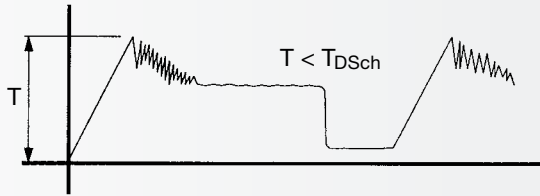

Alternating stress

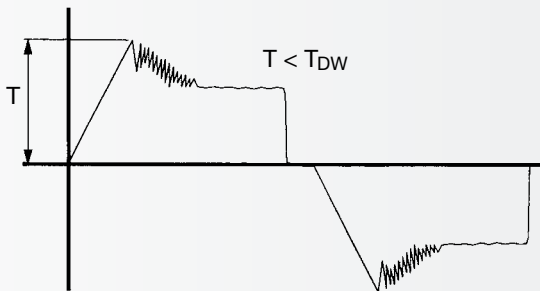

The maximum peak torque T_{SP} is the extremely rarely occurring torque of the system (crash, emergency case).

This maximum torque (T_{SP}) should not exceed the functional limited torque T_{CS} of the drive-shaft.

$$T_{SP} < T_{CS}$$

T_{SP} = Maximum peak torque [Nm]

T_N = Nominal torque [Nm]

T_{CS} = Functional limit torque of the driveshaft [Nm]
(see data sheets)

Service factor K

The service factors shown in the following tables should be used as approximate values only.

Light shock load: K = 1,1 – 1,5

Driven machines

- Centrifugal pumps
- Generators (continuous load)
- Conveyors (continuous load)
- Small ventilators
- Machine tools
- Printing machines

Medium shock load: K = 1,5 – 2

Driven machines

- Centrifugal pumps
- Generators (non-continuous load)
- Conveyors (non-continuous load)
- Medium ventilators
- Wood handling machines
- Small paper and textile machines
- Pumps (multi-cylinder)
- Compressors (multi-cylinder)
- Road and bar mills
- Locomotive primary drives

Heavy shock load: K = 2 – 3

Driven machines

- Large ventilators
- Marine transmissions
- Calender drives
- Transport roller tables
- Small pinch rolls
- Small tube mills
- Heavy paper and textile machines
- Compressors (single-cylinder)
- Pumps (single-cylinder)

Heavy shock load: K = 2 – 3

Driven machines

- Mixers
- Bucket wheel reclaimers
- Bending machines
- Presses
- Rotary drilling rigs
- Locomotive secondary drives
- Continuous casters
- Crane drives

Extra-heavy shock load: K = 3 – 5

Driven machines

- Continuous working roller tables
- Medium section mills
- Continuous slabbing and blooming mills
- Continuous heavy tube mills
- Reversing working roller tables
- Vibration conveyors
- Scale breakers
- Straightening machines
- Cold rolling mills
- Reeling drives
- Blooming stands

Extreme shock load: K = 5 – 10

Driven machines

- Feed roller drives
- Wrapper roll drives
- Plate-shears
- Reversing slabbing and blooming mills

Additional information and ordering instructions

Selection of driveshafts

The selection of a GWB™ driveshaft is determined not only by the maximum permissible torque of the shaft and the connections but also by a variety of other factors.



For the exact determination and selection of driveshafts, see the Selection of Driveshafts pages in this brochure.

Dana engineers can precisely calculate the correct size of the shaft and joint for your application with the use of computer programs created specifically for this purpose.

In order to best match your requirements, you'll be asked to provide the following information:

- Installation length of the driveshaft
- Maximum joint angle requirement
- Required length compensation
- Maximum rotation speed of the shaft
- Shaft end connection details
- Maximum torque to be transmitted
- Nominal torque to be transmitted
- Load occurrences
- Description of the equipment and working conditions

Specific applications

Driveshafts in railway transmissions

The selection of driveshafts in the secondary system of railway

vehicles must be based on the maximum torque that can be transmitted to the track (wheel slip or adhesion torque).

Driveshafts in crane travel drives

The particular operating conditions for travel drives of cranes have been taken into consideration in the DIN-standard 15450. As a result, driveshafts for these applications can be selected by using that standard.

Driveshafts in marine transmissions

These driveshafts are subject to acceptance and must correspond to the standards of the respective classification society.

Driveshafts for other forms of passenger conveyance

Driveshafts used in amusement park equipment, ski lifts or similar lift systems, elevators, and rail vehicles must be in accordance with the standards and specifications of the appropriate licensing and supervisory authorities.

Driveshafts in explosive environments (Atex-outline)

For the use of driveshafts in areas with danger of explosion, an EC-conformity certificate acc. to EC-outline 94/9/EG can be provided.

The possible categories for the product „driveshaft“ are:

- a) in general: $\text{CE} \otimes \text{II 3 GDc T6}$
- b) for driveshafts with adapted features: $\text{CE} \otimes \text{II 2 GDc T6}$

The driveshaft should not be used under the following operating conditions:

- Within the critical bending speed range of the drive
- Within the critical torsional speed range of the drive
- At operating angles which exceed the specified maximum (refer to drawing confirmed with order)
- At dynamic and static operating torques which exceed the specified limit (refer to drawing confirmed with order)
- At speed x deflection angle ($n \times \beta$) conditions which exceed the limit (refer to GWB catalogue)
- For usage time which exceeds the calculated bearing lifetime of the joint bearings

If you'd like more information on GWB driveshafts, or would like to discuss specific application requirements with an engineer, please call Dana at 0049(0)201-8124-0 or visit www.gwbdriveshaft.com, www.dana.com.





After-sales service Spicer Gelenkwellenbau GmbH

E-mail: industrial@dana.com, Web: www.gwbdriveshaft.com / www.dana.com

Mailing address: P.O. Box 10 13 62 - 45013 Essen / Germany

Office address: 2. Schnieringstraße 49 - 45329 Essen / Germany

Phone: 00 49 (0) 201-81 24 - 0, Fax: 00 49 (0) 201-81 24 - 652

Home Country

GKN Service International GmbH

D-22525 Hamburg

Ottensener Str. 150

Phone: 0 40-540 090-0

Fax: 0 40-540 090-44

Foreign Country

Argentina

Chilicote S.A.

Avda. Julio A. Roca 546

C1067ABN - Buenos Aires

Phone: 00 54-11-43 31-66 10

Fax: 00 54-11-43 31-42 78

E-mail: chilicote@chilicote.com.ar

Also responsible for Uruguay and Chile.

Australia

Hardy Spicer Company P/L

17-31 Discovery Road

Dandenong South, Victoria 3175

Phone: 00 61-3-97 941 900

Fax: 00 61-3-97 069 928

E-mail: russell.plowman@hardyspicer.com.au

Dana Australia Pty Ltd

39- 45 Wedgewood Road

Hallam, Victoria, 3803

Phone: 00 61-3-92 135 555

Fax: 00 61-3-92 135 588

www.dana.com.au

Austria

GKN Service Austria GmbH

Slamastraße 32

A-1230 Wien

Phone: 00 43-1-61 63 880-0

Fax: 00 43-1-61 63 880-15

Also responsible for Eastern Europe.

Belgium

GKN Service Benelux BV

Rue Emile Pathéstraat 410

B-1190 Brussel (Vorst-Forest)

Phone: 00 32-2-33 49 861

Fax: 00 32-2-33 49 888

Brazil

Dana Holding Corporation

Aftermarket - South America

Rua Ricardo Bruno Albarus, 201

Gravataí, RS Brazil 94045-400

Contact: Rodrigo Minozzo

Phone: 00 55-51 3489-3775

E-mail: rodrigo.minozzo@dana.com

China / P.R.C.

Dana China Shanghai Office

7F, Tower B, Hongwell International Plaza

No. 1602 Zhongshan Road West

Xuhui District, Shanghai, China

Phone: 00 86-21 333 250 00

Fax: 00 86-21 648 723 00

E-mail: shao.cheng@dana.com

China

Dana (Wuxi) Technology Co., Ltd.

No. 209 Xinzhou Road, Wuxi National

Hi-Technology Industrial

Development Zone, P.R. China

Phone: 00 86-510-886 560 00

Fax: 00 86-510-881 198 66

Denmark

GKN Service Scandinavia AB

Baldershøj 11 A+B

DK-2635 Ishøj

Phone: 00 45-44 866 844

Fax: 00 45-44 688 822

Finland

Oy UNILINK Ab

Vattuniemenkatu 15

00210 Helsinki

Phone: 00 358-9-68 66 170

Fax: 00 358-9-69 40 449

E-mail: unilink@unilink.fi

France

GKN Service France

Ecoparc Cettions-Secteur 1 Jaune

8 Rue Panhard et Levassor

78570 Chanteloup les Vignes, France

Phone: 00 33-1-30 068 434

Fax: 00 33-1-30 068 439

E-mail: serge.campestrini@gkn.com

Greece

Sokrates Mechanics GmbH

205, Piraeus Str.

GR-11853 Athens

Phone: 00 30-210-34 71 910

Fax: 00 30-210-34 14 554

E-mail: sokrates@enternet.gr

Hellas Cardan GmbH

Strofi Oreokastrou

GR-56430 Thessaloniki

Phone: 00 30-2310-682 702

Fax: 00 30-2310-692 972

E-mail: hecardan@otenet.gr

Great Britain

GKN Driveline Service Ltd.

Higher Woodcroft Leek,

GB-Staffordshire, ST13 5QF

Phone: 00 44-15 38-384 278

Fax: 00 44-15 38-371 265

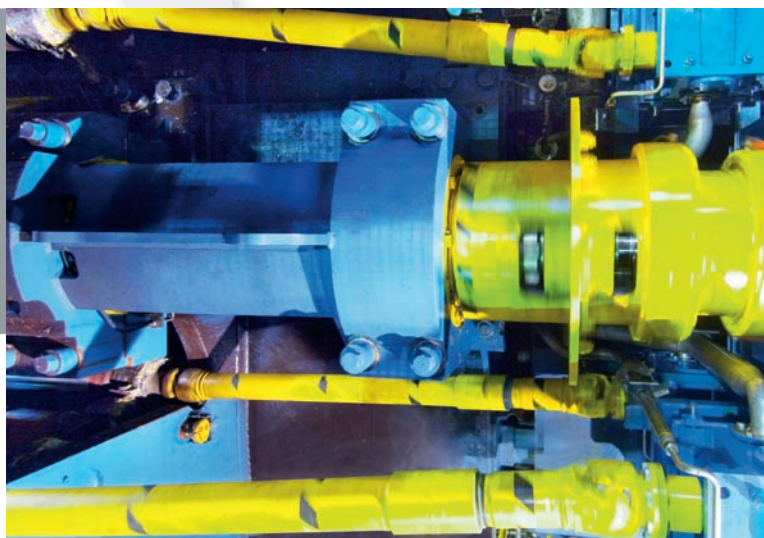

India**Dana India Private Limited**

Survey No. 278, Raison Industrial Park, Phase II,
Hinjewadi, Village-Mann, Tal. Mulshi,
Pune -411 057 (INDIA)
Phone: 00 91-20-30436255
E-mail: sgwb.india@dana.com

Italy**Uni-Cardan Italia S.p.A.**

Via G. Ferraris, 125/C
I-20021 Ospiate di Bollate (MI)
Phone: 00 39-02-383 381
Fax: 00 39-02-33 01030

Japan**Nakamura Jico Co. Ltd.**

10-10, Tsukiji, 3-chome
Chuo-Ku, Tokyo
Phone: 00 81-3-35 43-97 72
Fax: 00 81-3-35 43-97 79

Netherlands**GKN Service Benelux BV**

Haarlemmerstraatweg 155-159
NL-1165 MK Halfweg
Phone: 00 31-20-40 70 207
Fax: 00 31-20-40 70 217

Norway**GKN Service Scandinavia AB**

Karihaugveien 102
N-1086 Oslo
Phone: 00 47-23 286 810
Fax: 00 47-23 286 819

Russia-Ukraine**APA-KANDT GmbH**

Weidestr. 122a
D-22083 Hamburg
Phone: 00 49-40-48 061 438
Fax: 00 49-40-480 614 938
E-mail: office@apa-kandt.de
Web: www.apa-kandt.de

Sweden**GKN Service Scandinavia AB**

Alfred Nobels Allé 110
SE-14648 Tullinge
Phone: 00 46-86 039 700
Fax: 00 46-86 039 702

Switzerland**GKN Service International GmbH**

Althardstraße 141
CH-8105 Regensdorf
Phone: 00 41-44-871-60 70
Fax: 00 41-44-871-60 80

Spain**Gelenk Industrial S.A.**

Balmes, 152
E-08008 Barcelona
Phone: 00 349-3-23 74 245
Fax: 00 349-3-23 72 580
E-mail: javier.montoya@gelenkindustrial.com

South Africa**Driveline Technologies (Pty) Ltd.**

CNR, Derrick & Newton Roads
Spartan, Kempton Park
P.O. Box 2649
Kempton Park 1620
Phone: 00 27-11-929-56 00
Fax: 00 27-11-394-78 46
E-mail: richard@driveline.co.za

USA, Canada**Dana Spicer Service Parts**

P.O. Box 321
Toledo, OH 43697-0321
Phone: 001-800-621-80 84
Fax: 001-800-332-61 24
E-mail: tom.deHaven@dana.com



Copyright by Spicer Gelenkwellenbau GmbH

All rights reserved.

Any reproduction of this publication or parts thereof is subject to the explicit authorization of the copyright-holder.

This catalogue supersedes all former editions.

We reserve the right to make alterations.

Release 10/2014

Dana Holding Corporation

is a world-leading supplier of driveline, sealing, and thermal-management technologies that improve the efficiency and performance of passenger, commercial, and off-highway vehicles with both conventional and alternative-energy powertrains. The company's global network of engineering, manufacturing, and distribution facilities provides original-equipment and aftermarket customers with local product and service support. Based in Maumee, Ohio, Dana employs approximately 24,500 people in 26 countries and reported 2011 sales of \$7.6 billion.

About the Dana GWB™ Products

Dana produces GWB industrial drive-shafts and genuine service parts for the scrap steel, construction, railway, marine, and paper industries. Manufacturing and assembly operations in Germany are supported by Dana's global network of R&D and distribution facilities.

© 2012 Dana Limited



Trains



Industrial plants



Ships

Spicer Gelenkwellenbau GmbH

2. Schnieringstraße 49
45329 Essen/Germany

Phone: 00 49 (0) 201-81 24-0

Fax: 00 49 (0) 201-81 24-652

www.gwbdriveshaft.com

www.dana.com

GWB®

A Dana Brand 

APPLICATION POLICY

Capacity ratings, features, and specifications vary depending upon the model and type of service. Application approvals must be obtained from Dana. We reserve the right to change or modify our product specifications, configurations, or dimensions at any time without notice.