

## JAW - FLEX COUPLINGS TYPE RFC

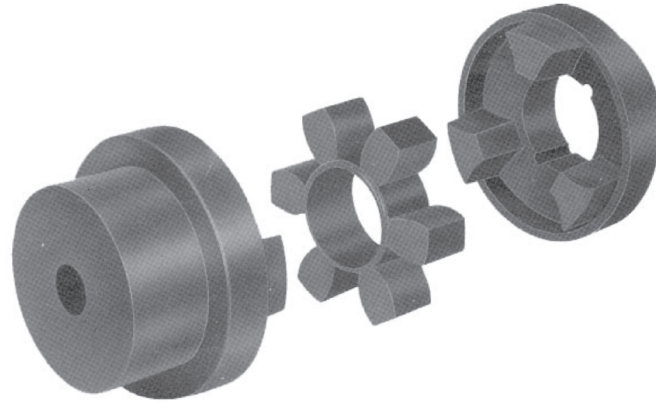

The RFC coupling is a general purpose flexible coupling available in eight different sizes in taper bore, pilot bore or finished bore.

### Easy installation

Alignment is quickly achieved by simply placing a straight edge across the outside diameter of the hubs. No special tools are needed, only a hexagon wrench for the locking of the taper bush.

### Accommodates Misalignment

The RFC coupling compensates for axial, parallel & angular misalignments.

### Extra protection Against Failure

The Inter-linking hubs act as an additional safeguard, though the flexible element fails, the drive will be maintained by the interaction of the jaws which are an integral part of the coupling hubs. The hubs are made of C. I.. Jaws are unmachined.

### Interchangeable

The RFC coupling is compatible with leading makes of couplings. Elastomeric spider is of Nitrile rubber having shore hardness of 80°, suitable for temperatures from -40° C to +100° C.

**TABLE 2. POWER RATING (kW)**

Speed rpm	Coupling Size							
	RFC 7	RFC 9	RFC 11	RFC 13	RFC 15	RFC 18	RFC 23	RFC 28
100	0.33	0.84	1.68	3.30	6.28	9.95	20.90	33.00
1500	4.95	12.55	25.15	49.50	94.00	149.00	313.50	495.00
3000	9.90	25.10	50.30	99.00	188.00	298.00	—	—

# JAW - FLEX COUPLINGS

## TYPE RFC

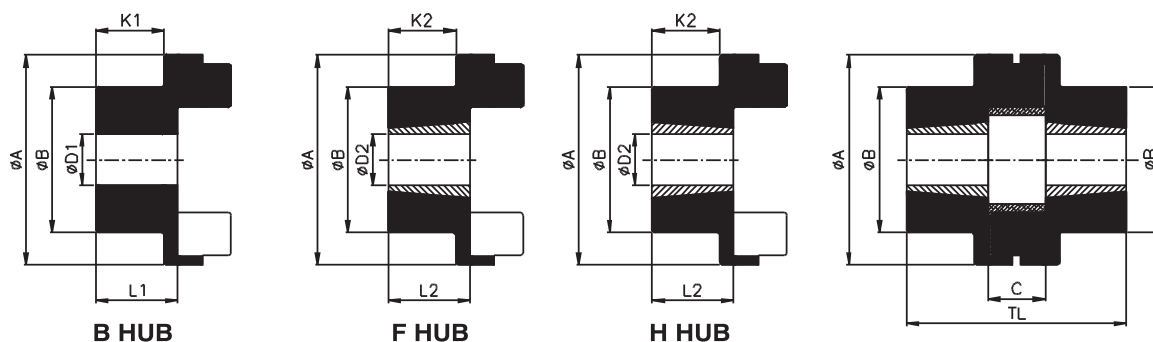

TABLE 3. DIMENSIONS DATA (mm)

Size	B Hub				F / H Hub					ØA	ØB	C	TL		
	Bore ØD1		K1	L1	#Bush Size	Bore ØD2		K2	L2				TL1	TL2	TL3
	Max.	Min.				Max.	Min.								
7	32	10	21	26	1008	25	10	19	24	69	60	17.5	66	68	70.0
9	42	10	26	32	1108	28	10	18	24	85	65	22.5	70.5	78.5	86.5
11	55	10	37	45	1610	42	14	19	27	112	100	29	83	101	119.0
13	60	20	46	55	1610	42	14	17.5	26.5	130	105	36	89	117.5	146.0
15	70	20	50	60	2012	50	14	24	34	150	115	40	108	134	160.0
18	80	30	58	70	2517	60	16	35	47	180	125	49	143	166	189.0
23	100	40	77	90	3020	75	24	39.5	52.5	225	155	58.5	163.5	201	238.5
28	115	50	88.5	105	3535	90	35	74.0	90.5	275	185	74.5	255.5	270	284.5

TABLE 4. TECHNICAL DATA

Size	Maximum Speed rpm	Torque Rating (Nm)		Moment of Inertia WR <sup>2</sup> (kgm <sup>2</sup> )	Torsional Stiffness (Nm / degree)	Maximum Misalignment		\$ Weight (kg)
		Normal	Maximum			Parallel	Axial	
RFC 7	8300	31.5	72	0.0003	10.2	0.3	+0.20	1.1
RFC 9	6740	80	180	0.001	25.5	0.3	+0.49	1.0
RFC 11	5110	160	360	0.003	48.0	0.3	+0.61	5.0
RFC 13	4400	315	720	0.006	84.0	0.4	+0.79	8.0
RFC 15	3820	600	1500	0.010	176.0	0.4	+0.92	11.7
RFC 18	3180	950	2350	0.022	240.0	0.4	+1.09	18.2
RFC 23	2540	2000	5000	0.065	336.0	0.5	+1.32	35.0
RFC 28	2080	3150	7200	0.191	960.0	0.5	+1.70	66.5

# Available only with taper bore, without taper bush.

\$ Weight and M.I. are at max bores with one type-B hub combination.

- NOTES :**
- TL1 = Combination of F-F / H-H / F-H hub
  - TL2 = Combination of B-F / B-H hub
  - TL3 = Combination of B-B hub