

BACKLASH FREE MINIATURE METAL BELLOWS COUPLINGS 0.05- 10 Nm



GENERAL INFORMATION R+W MINIATURE BELLOWS COUPLINGS:



SERVICE LIFE

R+W bellows couplings are fatigue resistant and wear free for an infinite service life, as long as the technical limits are not exceeded.

FIT CLEARANCE

Overall shaft / hub clearance of 0.01 - 0.05 mm

ROTATIONAL SPEED

Standard up to 10,000 rpm.
Over 10,000 rpm in finely balanced version; up to grade ISO G=2.5 is available.

TEMPERATURE RANGE

-30 to +100° C

SPECIAL SOLUTIONS





Various materials, tolerances, dimensions and performance ratings available for custom applications on request.

ATEX (Optional)

For use in hazardous zones 1/21 and 2/22, the metal bellows has been authorized under directive 94/9/EG and is available with certification.

BACKLASH FREE, TORSIONALLY STIFF MINIATURE COUPLINGS

0.05 - 10 Nm

MODEL		FEATURES	
MK1		<p>with radial set screws from 0.05 - 10 Nm</p> <ul style="list-style-type: none"> ▶ large bores available in small size ▶ integral dismounting groove eliminates the need for flats on shafts ▶ economy design 	Page 52
MK2		<p>with clamping hub from 0.5 - 10 Nm</p> <ul style="list-style-type: none"> ▶ easy mounting ▶ for highly dynamic applications ▶ finely balanced versions up to 90,000 rpm 	Page 53
MKH		<p>with split clamping hub from 0.5 - 10 Nm</p> <ul style="list-style-type: none"> ▶ lateral mounting possible ▶ easy installation and removal ▶ allows for pre-alignment of shafts 	Page 54
MK3		<p>with expanding shaft from 0.5 - 10 Nm</p> <ul style="list-style-type: none"> ▶ easy installation ▶ solution for mismatched shaft / bore diameters ▶ saves space and cost 	Page 55
MK4		<p>with radial set screw and blind mate connection from 0.5 - 10 Nm</p> <ul style="list-style-type: none"> ▶ axial installation possible ▶ electrically and thermally isolating ▶ includes integral dismounting groove 	Page 56

MODEL

FEATURES

MK5



with clamping hub and blind mate connection from 0.5 - 10 Nm

- ▶ axial installation possible
- ▶ electrically and thermally isolating
- ▶ easy mounting and dismounting

Page 57

MK6



with expanding shaft and blind mate connection from 0.5 - 10 Nm

- ▶ full axial installation possible
- ▶ well suited to restricted installation space
- ▶ solution to mismatched bore / shaft diameters

Page 58

MKS



with conical clamping ring from 4.5 - 10 Nm

- ▶ speeds up to 120,000 rpm
- ▶ naturally very well balanced due in part to self centering clamping system
- ▶ for high speed high precision applications

Page 59

BKL



with clamping hub up to 3 Nm

- ▶ low priced
- ▶ light weight and low moment of inertia
- ▶ temperatures up to 200° C

Page 60

FK1



with radial set screw up to 1 Ncm

- ▶ well balanced
- ▶ sterilizable

Page 61

MK1

WITH RADIAL SET SCREWS

0.05 - 10 Nm



PROPERTIES

FEATURES

- ▶ integral dismounting groove eliminates the need for flats on shafts
- ▶ economical design
- ▶ larger bore diameters in a small size possible

▶ **Hubs:** aluminium

DESIGN

Two hubs with radial set screws concentrically mounted to flexible bellows. Speeds up to 20,000 rpm; over 20,000 with finely balanced version.

MATERIAL

- ▶ **Bellows:** size 0.5 tombac; sizes 1 and up high grade stainless steel

Advantage:

Bore diameters above 4mm have an integral dismounting groove, which provides clearance over any burr which may be kicked up by the set screw, eliminating the need for flats on shafts.

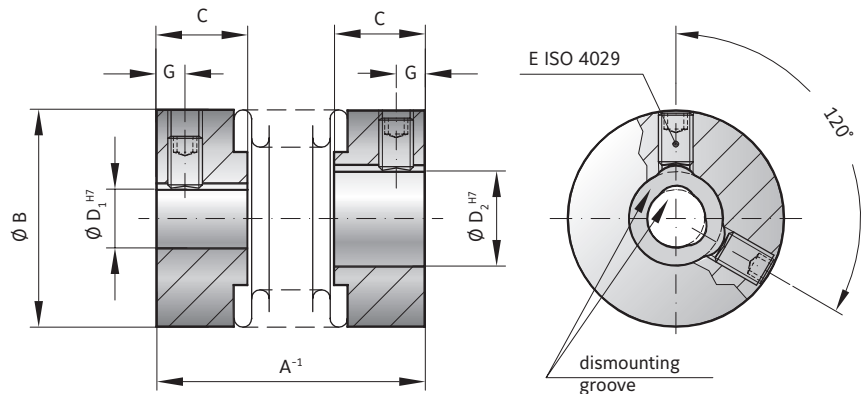
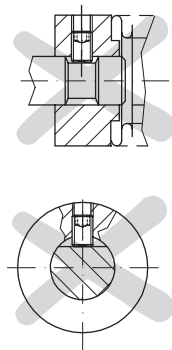

MODEL MK1

SIZE			0.5	1	5	10	15	20	45	100
Rated torque (Nm)	T_{KN}		0.05	0.1	0.5	1.0	1.5	2.0	4.5	10
Overall length (mm)	A^{-1}		14	20	20 23 26	22 25 28	24 29	26 31 35	37 45	43 53
Outside diameter (mm)	B		6.5	10	15	15	19	25	32	40
Fit length (mm)	C		4	5	6.5	6.5	7.5	11	13	15
Inside diameter possible from \varnothing to \varnothing H7 (mm)	$D_{1/2}$		1-3	1-5	3-9	3-9	3-12	3-16	6-22	6-28
Clamping screw ISO 4029			1xM2	1xM2.5	1xM3	1xM3	2xM3	2xM4	2xM5	2xM6
Tightening torque of the fastening screw (Nm)	E		0.35	0.75	1.3	1.3	1.3	2.5	4	6
Distance (mm)	G		1.5	1.8	2	2	2	2.5	3.5	4
Moment of inertia (gcm^2)	$J_{ges.}$		0.1	0.4	1.1 1.2 1.3	1.3 1.8 2	4.7 5.5	15 18 20	65 70	180 220
Approximate weight (g)			1	5	6 6 6	6 7 8	12 14	22 24 26	54 58	106 114
Torsional stiffness (Nm/rad)	C_t		50	70	280 210 170	510 380 320	750 700	1200 1300	1200 7000	5000 9050 8800
Axial (mm)			0.4	0.4	0.4 0.5 0.6	0.4 0.5 0.6	0.5 0.7	0.5 0.6 0.7	0.7 1	1 1 1.2
Lateral (mm)	Max. values		0.1	0.15	0.15 0.2 0.25	0.15 0.2 0.25	0.15 0.2	0.15 0.2 0.25	0.2 0.25	0.2 0.25 0.2 0.3
Angular (degree)			1	1	1 1.5 2	1 1.5 2	1.5 1.5	1.5 1.5	2 1.5 2	1.5 2 1.5 2

ORDERING EXAMPLE	MK1	5	26	4.76	5	XX
Model	●					
Size		●				
Overall length mm			●			
Bore D1 H7				●		
Bore D2 H7					●	
For custom features place an XX at the end of the part number and describe the special requirements (e.g. MK1 / 5 / 26 / 4.76 / 5 / XX; XX=finely balanced for 25,000 rpm)						

Special designation only (e.g. high speed balancing).

MK2

WITH CLAMPING HUB

0.5 - 10 Nm



PROPERTIES

FEATURES

- ▶ for highly dynamic applications
- ▶ easy installation
- ▶ light weight and low moment of inertia

DESIGN

Two clamping hubs concentrically mounted to flexible bellows.

MATERIAL

- ▶ **Bellows:** high grade stainless steel
- ▶ **Hubs:** aluminium

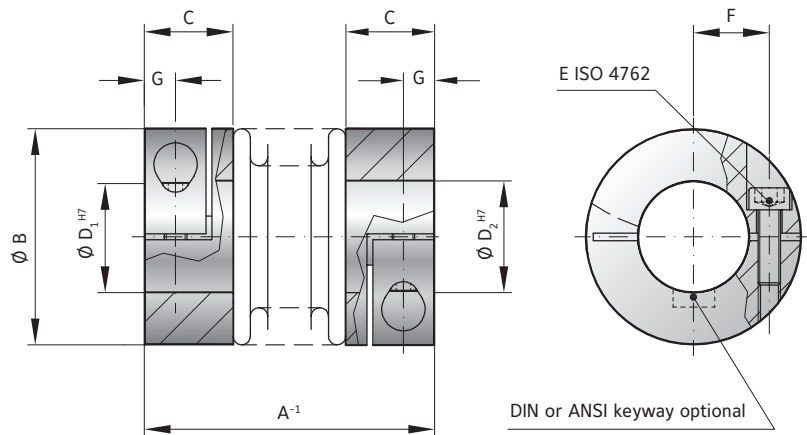

MINIATURE
COUPLINGS MK

MODEL MK2

SIZE		5			10			15		20			45		100	
Rated torque (Nm)	T_{KN}	0.5			1.0			1.5		2.0			4.5		10	
Overall length (mm)	A^{-1}	25	28	31	27	30	33	30	35	35	40	44	46	54	50	60
Outside diameter (mm)	B	15			15			19		25			32		40	
Fit length (mm)	C	9			9			11		13			16		16	
Inside diameter possible from \emptyset to \emptyset H7 (mm)	$D_{1/2}$	3-7			3-7			3-8		3-12.7			5-16		5-24	
Fastening screw ISO 4762	E	M2			M2			M2.5		M3			M4		M4	
Tightening torque of the fastening screw (Nm)		0.43			0.43			0.85		2.3			4		4.5	
Distance between centerlines (mm)	F	4.5			4.5			6		8			10		15	
Distance (mm)	G	3			3			3.5		4			5		5	
Moment of inertia (gcm ²)	J_{ges}	2.6	2.8	3	3	3.4	3.6	8.5	9.5	25	27	29	100	108	160	205
Approximate weight (g)		9	9	9	9	10	11	22	24	36	38	40	74	78	120	130
Torsional stiffness (Nm/rad)	C_T	280	210	170	510	380	320	750	700	1200	1300	1200	7000	5000	9050	8800
Axial (mm)	Max. values	0.4	0.5	0.6	0.4	0.5	0.6	0.5	0.7	0.5	0.6	0.7	0.7	1	1	1.2
Lateral (mm)		0.15	0.2	0.25	0.15	0.2	0.25	0.15	0.2	0.15	0.2	0.25	0.2	0.25	0.2	0.3
Angular (degree)		1	1.5	2	1	1.5	2	1.5	1.5	1.5	1.5	2	1.5	2	1.5	2

ORDERING EXAMPLE	MK2	5	25	4.76	5	XX
Model	●					Special designation only (e.g. special bore tolerance).
Size		●				
Overall length mm			●			
Bore D1 H7				●		
Bore D2 H7					●	

For custom features place an XX at the end of the part number and describe the special requirements (e.g. MK2 / 5 / 25 / 4.76 / 5 / XX; XX=finely balanced for 25,000 rpm)



PROPERTIES

FEATURES

- ▶ mounts laterally
- ▶ allows for pre-alignment of shafts
- ▶ light weight and low moment of inertia

DESIGN

Two fully split clamping hubs, with two screws in each, concentrically mounted to flexible bellows.

MATERIAL

- ▶ **Bellows:** high grade stainless steel
- ▶ **Hubs:** aluminium

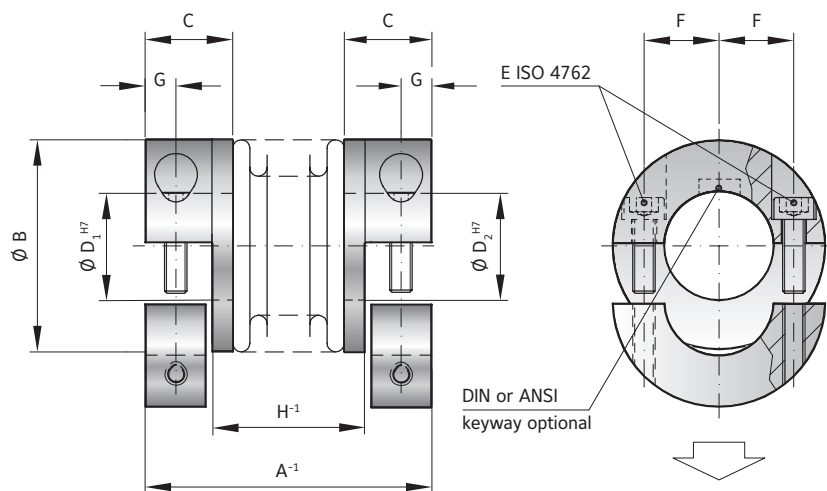

MODEL MKH

SIZE	5			10			15			20			45		100	
Rated torque (Nm)	0.5			1.0			1.5			2.0			4.5		10	
Overall length (mm)	25	28	31	27	30	33	30	35	35	40	44	46	54	50	60	
Outside diameter (mm)	15			15			19			25			32		40	
Fit length (mm)	9			9			11			13			16		16	
Inside diameter possible from Ø to Ø H7 (mm)	3-7			3-7			3-8			3-12.7			5-16		5-24	
Fastening screw ISO 4762	M2			M2			M2.5			M3			M4		M4	
Tightening torque of the fastening screw (Nm)	0.43			0.43			0.85			2.3			4		4.5	
Distance between centerlines (mm)	4.5			4.5			6			8			10		15	
Distance (mm)	3			3			3.5			4			5		5	
Distance (H)	12	15	18	14	17	20	14.5	19.5	17	22	26	23.5	31.5	27.5	37.5	
Moment of inertia (gcm ²)	2.6	2.8	3	3	3.4	3.6	8.5	9.5	25	27	29	100	108	160	205	
Approximate weight (g)	9	9	9	9	10	11	22	24	36	38	40	74	78	120	130	
Torsional stiffness (Nm/rad)	280	210	170	510	380	320	750	700	1200	1300	1200	7000	5000	9050	8800	
Axial (mm)	0.4	0.5	0.6	0.4	0.5	0.6	0.5	0.7	0.5	0.6	0.7	0.7	1	1	1.2	
Lateral (mm)	0.15	0.2	0.25	0.15	0.2	0.25	0.15	0.2	0.15	0.2	0.25	0.2	0.25	0.2	0.3	
Angular (degree)	1	1.5	2	1	1.5	2	1.5	1.5	1.5	1.5	2	1.5	2	1.5	2	

ORDERING EXAMPLE	MKH	20	35	8	9.53	XX
Model	●					Special designation only (e.g. special bore tolerance).
Size		●				
Overall length mm			●			
Bore D1 H7				●		
Bore D2 H7					●	

For custom features place an XX at the end of the part number and describe the special requirements (e.g. MKH / 20 / 35 / 8 / 9.53 / XX; XX=finely balanced for 25,000 rpm)

MK3

WITH EXPANDING SHAFT 0.5 - 10 Nm



PROPERTIES

FEATURES

- ▶ for hollow shaft mounting
- ▶ easy to install
- ▶ light weight and low moment of inertia

▶ **Expanding shaft:** steel

DESIGN

One clamping hub with one clamping screw, one expanding shaft system, both concentrically mounted to flexible bellows.

MATERIAL

- ▶ **Bellows:** high grade stainless steel
- ▶ **Clamping hub:** aluminium

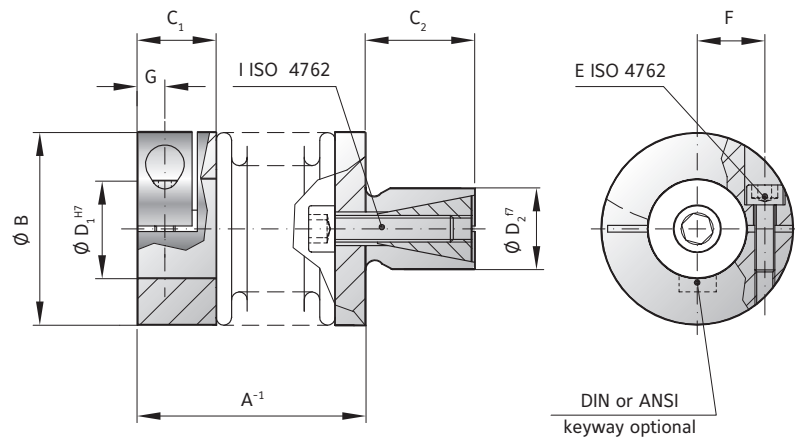

MINIATURE
COUPLINGS MK

MODEL MK3

SIZE		5			10			15			20			45		100	
Rated torque (Nm)	T_{KH}	0.5			1			1.5			2			4.5		10	
Overall length (mm)	A^{-1}	20	23	26	22	25	28	24	30	27	33	36	36	44	41	51	
Outside diameter (mm)	B	15			15			19			25			32		40	
Fit length (mm)	C_1	9			9			11			13			16		16	
Shaft length (mm)	C_2	10			10			12			12			15		20	
Inside diameter possible from \emptyset to \emptyset H7 (mm)	D_1	3-7			3-7			4-8			4-12.7			5-16		6-24	
Standard shaft possible from \emptyset to \emptyset f7 (mm)	D_2	8-10			8-10			10-14			10-16			14-20		16-24	
Fastening screw ISO 4762	E	M2			M2			M2.5			M3			M4		M4	
Tightening torque of the fastening screw (Nm)		0.43			0.43			0.85			2.3			4		4.5	
Distance between centerlines (mm)	F	4.5			4.5			6			8			10		15	
Distance (mm)	G	3			3			3.5			4			5		5	
Fastening screw ISO 4762	I	M3			M3			M4			M4			M5		M6	
Tightening torque of the fastening screw (Nm)		1.5			1.5			3			4			6.5		11	
Moment of inertia (gcm ²)	$J_{res.}$	2.6	2.8	3.0	3.0	3.4	3.6	8.5	9.5	25	27	29	100	108	160	205	
Torsional stiffness (Nm/rad)	C_T	280	210	170	510	380	320	750	700	1200	1300	1200	7000	5000	9050	8800	
Axial (mm)	Max. values	0.4	0.5	0.6	0.4	0.5	0.6	0.5	0.7	0.5	0.6	0.7	0.7	1	1	1.2	
Lateral (mm)		0.15	0.2	0.25	0.15	0.2	0.25	0.15	0.2	0.15	0.2	0.25	0.2	0.25	0.2	0.3	
Angular (degree)		1	1.5	2	1	1.5	2	1.5	1.5	1.5	1.5	2	1.5	2	1.5	2	

ORDERING EXAMPLE	MK3	20	36	6.35	12	XX
Model	●					Special designation only (e.g. special bore / shaft tolerance).
Size		●				
Overall length mm			●			
Bore D1 H7				●		
Shaft D2 f7					●	

For custom features place an XX at the end of the part number and describe the special requirements (e.g. MK3 / 20 / 36 / 6.35 / 12 / XX; XX=finely balanced for 25,000 rpm)

MK4

BLIND MATE WITH RADIAL SET SCREWS

0.5 - 10 Nm

PROPERTIES

FEATURES

- ▶ easy installation and removal
- ▶ electrically and thermally isolating
- ▶ absolutely backlash free assembly

MATERIAL

- ▶ **Bellows:** high grade stainless steel
- ▶ **Hubs:** aluminium
- ▶ **Tapered male segment:** high strength plastic

DESIGN

Two hubs with radial set screws, one of which has a tapered male projection for blind mate connection. Speeds up to 20,000 rpm; over 20,000 with finely balanced version.

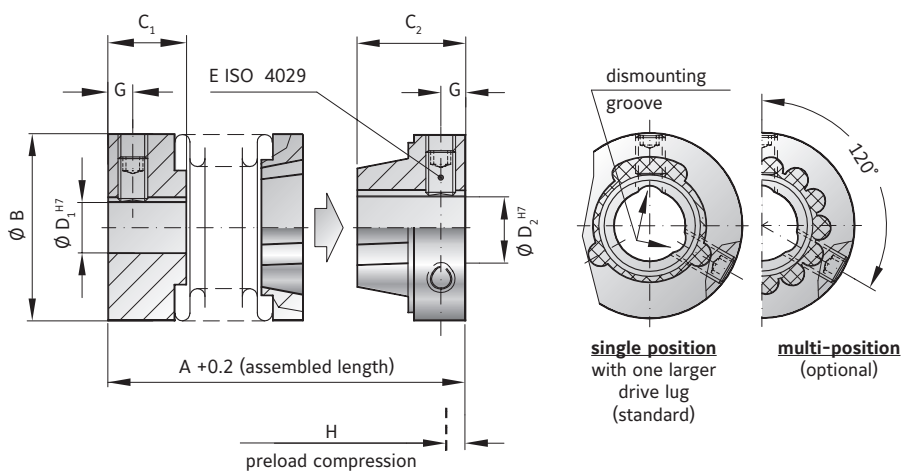

MODEL MK4

SIZE		5			15		20			45		100	
Rated torque	(Nm) T_{KN}	0.5			1.5		2			4.5		10	
Overall length (inserted)	(mm) $A^{+0.2}$	22	25	28	26	31	28	33	37	39	47	46	56
Outside diameter	(mm) B	15			19		25			32		40	
Fit length	(mm) C_1	6.5			7.5		11			13		15	
Fit length	(mm) C_2	9			10		11			14		16	
Inside diameter possible from \emptyset to \emptyset H7	(mm) D_1	3-9			3-12		3-16			6-22		6-28	
Inside diameter possible from \emptyset to \emptyset H7	(mm) D_2	3-6.35			3-9		3-12.7			6-16		6-20	
Clamping screw ISO 4029	E	1xM3			2xM3		2xM4			2xM5		2xM6	
Tightening torque of the fastening screw	(Nm)	1.3			1.3		2.5			4		6	
Distance	(mm) G	2			2		2.5			3.5		4	
Preload compression	(mm) H	0.4			0.5		0.5			0.7		1	
Axial recovery force at max. preload compression	(N)	5	3	2	4	3	3	4	3	15	10	25	30
Moment of inertia	(gcm ²) J_{ges}	2.0	2.2	2.5	5.5	6.0	21	23	25	80	85	200	210
Torsional stiffness	(Nm/rad) C_T	280	210	170	750	700	1200	1300	1200	7000	5000	9050	8800
Axial*	(mm)	0.4	0.5	0.6	0.5	0.7	0.5	0.6	0.7	0.7	1	1	1.2
Lateral	(mm) Max. values	0.15	0.2	0.25	0.15	0.2	0.15	0.2	0.25	0.2	0.25	0.2	0.3
Angular	(degree)	1	1.5	2	1.5	1.5	1.5	1.5	2	1.5	2	1.5	2

* in addition to maximum pretensioning

ORDERING EXAMPLE	MK4	20	37	8	9.53	XX
Model	●					
Size		●				
Overall length mm			●			
Bore D1 H7				●		
Bore D2 H7					●	

Special designation only (e.g. special bore tolerance).

For custom features place an XX at the end of the part number and describe the special requirements (e.g. MK4 / 20 / 37 / 8 / 9.53 / XX; XX=finely balanced for 25,000 rpm)

MK5

BLIND MATE WITH CLAMPING HUB

0.5 - 10 Nm

PROPERTIES



FEATURES

- ▶ easy installation and removal
- ▶ electrically and thermally isolating
- ▶ absolutely backlash free assembly

DESIGN

Two clamping hubs, one of which has a tapered male projection for blind mate connection.

MATERIAL

- ▶ **Bellows:** high grade stainless steel
- ▶ **Hubs:** aluminium
- ▶ **Tapered male segment:** high strength plastic

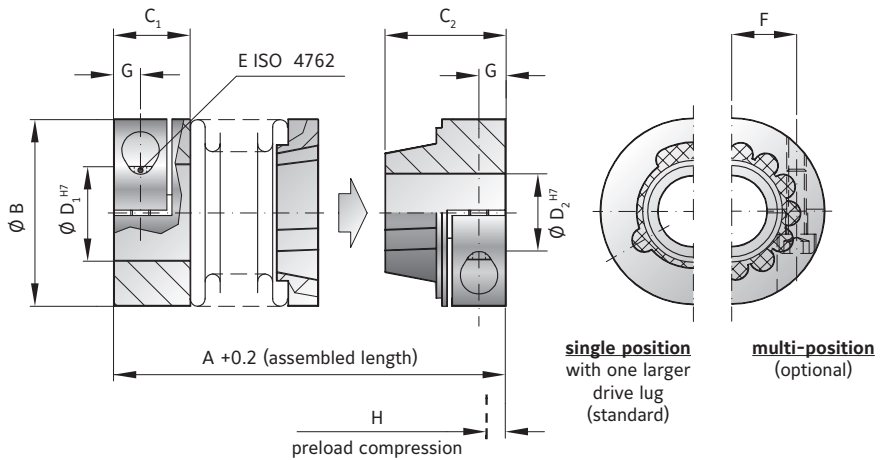

MINIATURE COUPLINGS MK

MODEL MK5

SIZE	5			15		20			45		100			
Rated torque (Nm)	T _{KN}		0.5		1.5		2		4.5		10			
Overall length (inserted) (mm)	A ^{+0.2}		27	30	33	34	39	37	43	46	49	57	55	65
Outside diameter (mm)	B		15			19		25			32		40	
Fit length (mm)	C ₁		9			11		13			16		16	
Fit length (mm)	C ₂		12			14		16			20		21.5	
Inside diameter possible from Ø to Ø H7 (mm)	D ₁		3-7			3-8		3-12.7			5-16		5-24	
Inside diameter possible from Ø to Ø H7 (mm)	D ₂		3-6.35			3-8		3-12.7			5-16		5-20	
Fastening screw ISO 4762	E		M2			M2.5		M3			M4		M4	
Tightening torque of the fastening screw (Nm)	E		0.43			0.85		2.3			4		4.5	
Distance between centerlines (mm)	F		4.5			6		8			10		15	
Distance (mm)	G		3			3.5		4			5		5	
Preload compression (mm)	H		0.4			0.5		0.5			0.7		1	
Axial recovery force at max. preload compression (N)			5	3	2	4	3	3	4	3	15	10	25	30
Moment of inertia (gcm ²)	J _{ges}		3.0	3.2	3.5	9.0	10	28	30	33	110	120	220	230
Torsional stiffness (Nm/rad)	C _T		280	210	170	750	700	1200	1300	1200	7000	5000	9050	8800
Axial* (mm)	Max. values		0.4	0.5	0.6	0.5	0.7	0.5	0.6	0.7	0.7	1	1	1.2
Lateral (mm)	Max. values		0.15	0.2	0.25	0.15	0.2	0.15	0.2	0.25	0.2	0.25	0.2	0.3
Angular (degree)	Max. values		1	1.5	2	1.5	1.5	1.5	1.5	2	1.5	2	1.5	2

* in addition to maximum pretensioning

ORDERING EXAMPLE	MK5	20	37	6	9.53	XX
Model	●					
Size		●				
Overall length mm			●			
Bore D1 H7				●		
Bore D2 H7					●	

Special designation only (e.g. special bore tolerance).

For custom features place an XX at the end of the part number and describe the special requirements (e.g. MK5 / 20 / 37 / 6 / 9.53 / XX; XX=finely balanced for 25,000 rpm)

MK6

BLIND MATE WITH EXPANDING SHAFT

0.5 - 10 Nm

PROPERTIES



FEATURES

- ▶ easy installation and removal
- ▶ solution for mismatched bore / shaft diameters
- ▶ absolutely backlash free assembly

- ▶ **Tapered male segment:** high strength plastic
- ▶ **Clamping hub:** aluminium
- ▶ **Expanding shaft:** steel

MATERIAL

- ▶ **Bellows:** high grade stainless steel

DESIGN

One clamping hub with a tapered male projection for blind mate connection and one expanding shaft system.

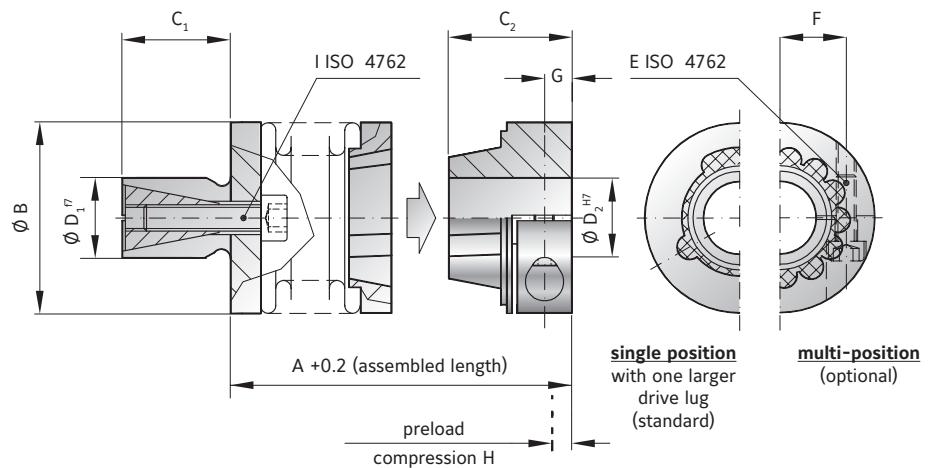

MODEL MK6

SIZE		5			15		20			45		100			
Rated torque	(Nm)	T_{KN}		0.5		1.5		2		4.5		10			
Overall length (inserted)	(mm)	$A^{+0.2}$		21	24	27	27	32	28	34	38	38	46	45	55
Outside diameter	(mm)	B		15		19		25		32		40			
Shaft length	(mm)	C_1		10		12		12		15		20			
Fit length	(mm)	C_2		12		14		16		20		21.5			
Standard shaft $\varnothing f7$	(mm)	D_1		8-10		10-14		10-16		14-20		16-24			
Inside diameter possible from \varnothing to $\varnothing H7$	(mm)	D_2		3-6.35		3-8		3-12.7		5-16		5-20			
Fastening screw ISO 4762		E		M2		M2.5		M3		M4		M4			
Tightening torque of the fastening screw	(Nm)	E		0.43		0.85		2.3		4		4.5			
Distance between centerlines	(mm)	F		4.5		6		8		10		15			
Distance	(mm)	G		3		3.5		4		5		5			
Preload compression	(mm)	H		0.4		0.5		0.5		0.7		1			
Axial recovery force at max. preload compression	(N)			5	3	2	4	3	3	4	3	15	10	25	30
Fastening screw ISO 4762		I		M3		M4		M4		M5		M6			
Tightening torque of the fastening screw	(Nm)	I		1.5		3		4		6.5		11			
Moment of inertia	(gcm ²)	J_{ges}		3.0	3.2	3.5	9.0	10	28	30	33	110	120	220	230
Torsional stiffness	(Nm/rad)	C_T		280	210	170	750	700	1200	1300	1200	7000	5000	9050	8800
Lateral	(mm)	Max. values		0.15	0.2	0.25	0.15	0.2	0.15	0.2	0.25	0.2	0.25	0.2	0.3
Angular	(degree)	Max. values		1	1.5	2	1.5	1.5	1.5	1.5	2	1.5	2	1.5	2

ORDERING EXAMPLE	MK6	20	28	12	9.53	XX
Model	●					Special designation only (e.g. special bore / shaft tolerance).
Size		●				
Overall length mm			●			
Shaft D1 f7				●		
Bore D2 H7					●	

For custom features place an XX at the end of the part number and describe the special requirements (e.g. MK6 / 20 / 28 / 12 / 9.53 / XX; XX=finely balanced for 25,000 rpm)

WITH CONICAL CLAMPING RING

4.5 - 10 Nm



High speed

PROPERTIES

FEATURES

- ▶ for high speeds
- ▶ self centering conical clamping ring design
- ▶ high balancing grade

DESIGN

Two hubs with conical clamping ring and three or four screws. Maximum speed up to 120,000 rpm.

MATERIAL

- ▶ **Bellows:** high grade stainless steel
- ▶ **Hubs and clamping rings:** aluminium

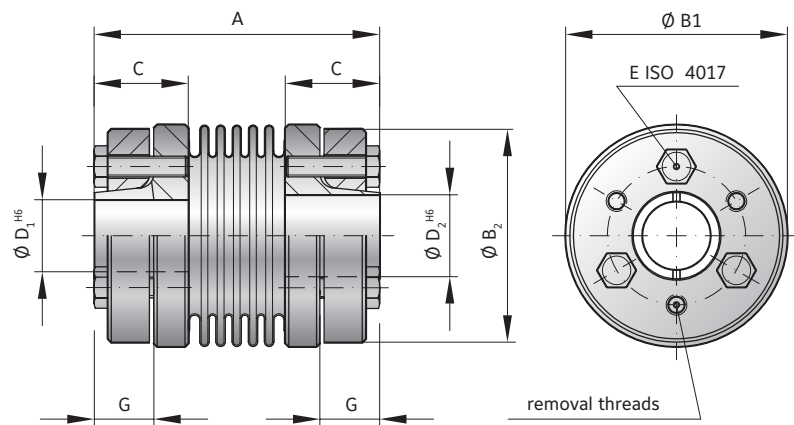

MODELL MKS

SIZE			45	100	150	
Rated torque (Nm)	T _{KN}		4.5	10	15	
Overall length (mm)	A		42	48	53	
Outside diameter (mm)	B ₁		32	40	49	
Outside diameter of hub (mm)	B ₂		30	38	46	
Fit length (mm)	C		14	16	20	
Inside diameter possible from Ø to Ø H6 (mm)	D _{1/2}		6-10	8-14	10-19	
Fastening screw ISO 4017 (mm)			3x M3	4x M3	8x M3	
Tightening torque of the fastening screw (Nm)	E		1.3	1.3	1.3	
Distance (mm)	G		8.5	9.5	13	
Moment of inertia (gcm ²)	J _{ges.}		65	226	561	
Masse (g)			51	103	171	
Torsional stiffness (Nm/rad)	C _r		7000	9050	23000	
Axial (mm)			0.5	0.75	0.75	
Lateral (mm)	Max. values		0.1	0.05*	0.1	0.05*
Angular (degree)			0.5	0.5	0.5	

For speeds beyond 50,000 rpm use reduced misalignment values marked with *

ORDERING EXAMPLE	MKS	45	8	9.53	XX
Model	●				
Size		●			
Bore D1 H6			●		
Bore D2 H6				●	
Special designation only (e.g. special bore tolerance).					
For custom features place an XX at the end of the part number and describe the special requirements (e.g. MKS / 45 / 8 / 9.53 / XX; XX=anodized aluminum hubs)					

BKL/003

ECOFLEX® WITH CLAMPING HUB 3 Nm



PROPERTIES

FEATURES

- ▶ economically priced
- ▶ backlash free and torsionally stiff
- ▶ wear free and robust

DESIGN

Two clamping hubs, each with a clamping screw.
Operational from -40 to +200° C

MATERIAL

- ▶ **Bellows:** high grade stainless steel
- ▶ **Hubs:** aluminium

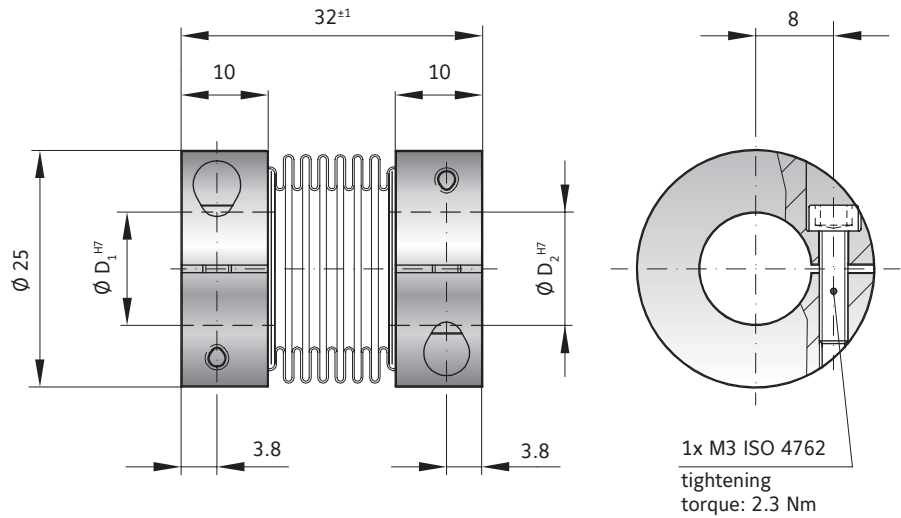

MODEL BKL/003

SIZE			3
Rated torque	(Nm)	T_{KN}	3
Standard bore diameters H7	(mm)	D_1, D_2	3 to 12.7
Moment of inertia	(gcm ²)	$J_{ges.}$	20
Approximate weight	(g)		23
Tightening torque of the fastening screws	(Nm)		2.3
Torsional stiffness	(Nm/rad)	C_T	994
Axial	(mm)	Max. values	1
Lateral	(mm)		0.2
Angular	(degree)		2

ECOFLEX®:

The low cost alternative for encoders, potentiometers, stepper motors, and small servo drives.

ORDERING EXAMPLE	BKL	003	3	6.35	XX
Model	●				
Size		●			
Bore D1 H7			●		
Bore D2 H7				●	
For custom features place an XX at the end of the part number and describe the special requirements (e.g. BKL / 003 / 3 / 6.35 / XX; XX=stainless steel hubs)					

FK1

MICROFLEX WITH RADIAL SET SCREWS

1 Ncm



PROPERTIES

FEATURES

- ▶ very small dimensions
- ▶ backlash free
- ▶ vibration damping

MATERIAL

- ▶ **Flex element:** high strength Polyamide
- ▶ **Hubs:** stainless steel

DESIGN

Two hubs with set screws mounted to a flex beam segment. Operational from -35° to +80° C. Speeds up to 20,000 rpm *

SPECIAL SOLUTION

Effective outside diameter can be reduced to 4.5mm through the use of M2x1.5mm screws.

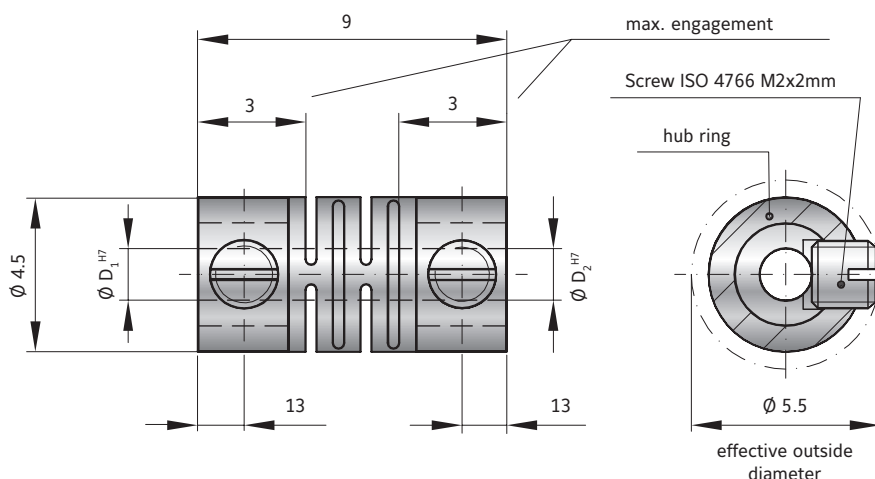

MINIATURE COUPLINGS MK

MODEL FK1/001/9

SIZE			
Rated torque	(Ncm)	T_{KN}	1
Standard bore H7	(mm)	D_1, D_2	1.5 / 1.5 or 2 / 1.5 additional bore diameters available upon request
Moment of inertia	(gcm ²)	$J_{ges.}$	5.39
Approximate weight	(g)		0.47
Torsional stiffness	(Ncm/rad)	C_T	23 (measured at +20° C)
Axial	(mm)	Max. values	0.2
Lateral	(mm)		0.1
Angular	(degree)		1.5

COUPLING ASSEMBLY AND MOUNTING

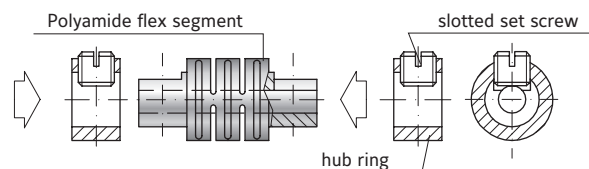

The screw threads through the clamping ring, through a slot in the flexible segment, and down onto the shaft, securing the entire assembly. Including a flat on the shaft can improve torque transmission.

Caution: Always use a precisely calibrated torque wrench during installation.

ORDERING EXAMPLE	FK1	001	9	1.5	1.5	XX
Model	●					Special designation only (e.g. special screw size).
Size		●				
Overall length mm			●			
Bore D1 H7				●		
Bore D2 H7					●	

For custom features place an XX at the end of the part number and describe the special requirements (e.g. FK1 / 001 / 9 / 1.5 / 1.5 / XX; XX=M2x1.5mm screws)

DISMOUNTING

For dismounting, simply loosen the set screws and remove the coupling from the shafts.

