

THE COUPLING.



**BACKLASH FREE  
SERVO DISC PACK COUPLINGS  
25 – 100 Nm**

**SCL**

**PRECISION  
COUPLINGS**



# BACKLASH FREE SERVO DISC PACK COUPLINGS 25 - 100 Nm

## GENERAL INFORMATION R+W SERVO DISC PACK COUPLINGS:



### SERVICE LIFE

R+W servo disc pack couplings are fatigue resistant and wear free for an infinite service life, as long as the technical limits are not exceeded.

### FIT CLEARANCE

Overall shaft / hub clearance of 0.01 - 0.05 mm

### ROTATIONAL SPEED

Standard up to 10,000 rpm.

### TEMPERATURE RANGE

-30 to +130° C

### SPECIAL SOLUTIONS

On request.

### ATEX (Optional)

On request.



## BACKLASH FREE SERVO DISC PACK COUPLINGS 25 – 100 Nm

MODEL		FEATURES	
<b>SCL2 S</b>		<b>with clamping hub single flex coupling</b> <ul style="list-style-type: none"><li>▶ very high torsional stiffness</li><li>▶ compact design</li><li>▶ low moment of inertia</li></ul>	Page 66
<b>SCL2 D</b>		<b>with clamping hub double flex coupling</b> <ul style="list-style-type: none"><li>▶ high torsional stiffness</li><li>▶ low moment of inertia</li><li>▶ lateral misalignment compensation</li></ul>	Page 66
<b>SCL3 S</b>		<b>with conical clamping system single flex coupling</b> <ul style="list-style-type: none"><li>▶ very high concentricity</li><li>▶ high clamping pressure</li><li>▶ low moment of inertia</li></ul>	Page 67
<b>SCL3 D</b>		<b>with conical clamping system double flex coupling</b> <ul style="list-style-type: none"><li>▶ high concentricity</li><li>▶ high clamping pressure</li><li>▶ high torsional stiffness</li></ul>	Page 67

## SERVO DISC PACK COUPLINGS

### SYMBOLS

- $T_{KN}$  = Rated torque of the coupling (Nm)
- $T_{AS}$  = Peak torque of the drive system e.g. max. acceleration torque of drive (Nm) or max. braking torque of load (Nm)
- $J_L$  = Total load inertia (e.g. spindle + slide + workpiece + 1/2 of coupling) (kgm<sup>2</sup>)
- $J_A$  = Total driving inertia (motor [including gear ratio] + 1/2 of coupling) (kgm<sup>2</sup>)
- $C_T$  = Torsional stiffness of the coupling (Nm/rad)
- $f_e$  = Natural frequency of the two mass system (Hz)

### ACCORDING TO TORQUE

Couplings are normally sized for the highest torque to be regularly transmitted. The peak torque of the application should not exceed the rated torque of the coupling. The following calculation provides an approximation of the minimum required coupling size, and allows for the maximum rated speed and misalignment to exist in the application:

$$T_{KN} \cong 1.5 \cdot T_{AS} \text{ (Nm)}$$

### ACCORDING TO ACCELERATION TORQUE

A more detailed calculation takes acceleration and the driving and driven moments of inertia into account. A strong inertia ratio diminishes the effect of the load factor in the sizing calculation.

$$T_{KN} \cong T_{AS} \cdot \frac{J_L}{J_A + J_L} \text{ (Nm)}$$

### ACCORDING TO RESONANT FREQUENCY

The torsional natural frequency of the coupling must be significantly higher or lower than that of the equipment. For the mechanical substitution model the two mass system applies.

$$f_e = \frac{1}{2 \cdot \pi} \sqrt{C_T \cdot \frac{J_A + J_L}{J_A \cdot J_L}} \text{ (Hz)}$$

In practice the following applies:  $f_e \geq 2 \cdot f_{er}$

Two Mass System

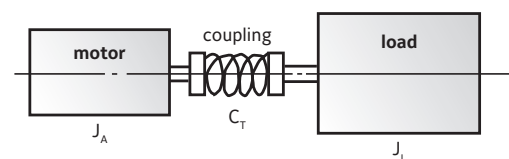

# SCL2

## WITH CLAMPING HUB 25 - 100 Nm



**NEW**

### PROPERTIES

#### FEATURES

- ▶ high torsional stiffness
- ▶ low inertia
- ▶ backlash free

#### MATERIAL

- ▶ **Disc packs:** highly elastic steel
- ▶ **Hubs and spacer:** aluminium

#### DESIGN

Two precision machined coupling hubs and precision spacer mounted to the disc packs by means of high strength screws and spacers for frictional clamping of the assembly.

Also available as split clamping hub.

S = Single flex coupling

D = Double flex coupling

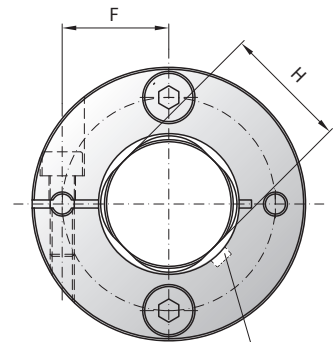
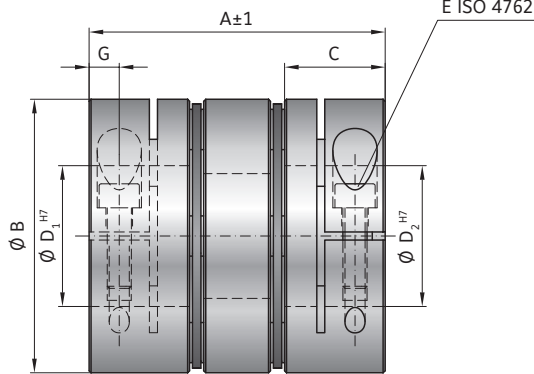
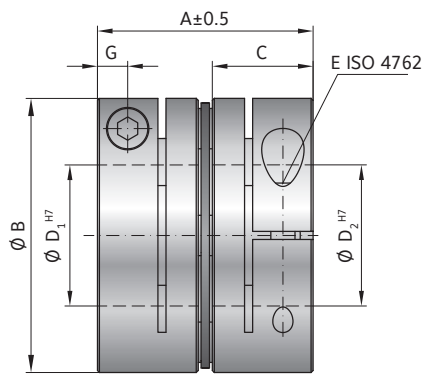

## MODEL SCL2

SIZE		25		40		60		100	
System		S	D	S	D	S	D	S	D
Rated torque (Nm)	$T_{KN}$	25		40		60		100	
Maximum torque (mm)	$T_{Kmax}$	37.5		60		90		150	
Coupling length (mm)	A	43.6	60.2	50.9	69.3	53.5	73.6	68.7	98.8
Outside diameter (mm)	B	56		63		68		82	
Fit length (mm)	C	20.2		24		25		30	
Bore diameter H7 (mm)	$D_1 / D_2$	15-30		16-30		25-35		26-40	
Fastening screw	E	M5		M6		M6		M8	
Tightening torque (Nm)		8		15		15		30	
Distance (mm)	F	22		23		26.5		28	
Distance (mm)	G	6		7.5		7.5		8.5	
Shaft diameter limitation (mm)	H	26		-		31		38	
Moment of inertia ( $10^{-3} \text{ kgm}^2$ )	$J_{ges}$	0.095	0.138	0.182	0.256	0.260	0.373	0.706	1.036
Weight (kg)		0.192	0.284	0.304	0.428	0.363	0.531	0.694	1.022
Torsional stiffness (Nm/rad)	$C_T$	46000	23000	58000	29000	82000	41000	157000	78500
Axial displacement $\pm$ (mm)		0.4	0.81	0.42	0.85	0.5	1	0.5	1.15
Lateral displacement $\pm$ (mm)	max. values	-	0.29	-	0.32	-	0.35	-	0.53
Angular displacement $\pm$ (degree)		1	2	1	2	1	2	1	2
Max. speed (1/min)		10000							

ORDERING EXAMPLE	SCL2	60	D	28	33	XX
Model	●					Special designation only (e.g. balanced G2.5)
Size		●				
System			●			
Bore $\varnothing$ D1 H7				●		
Bore $\varnothing$ D2 H7					●	

For custom features place an XX at the end of the part number and describe the special requirements (SCL2 / 60 / D / 28 / 33 / XX)

# SCL3

## WITH EXTERNAL CLAMPING RING

25 - 100 Nm

### PROPERTIES



**NEW**

#### FEATURES

- ▶ high torsional stiffness
- ▶ low inertia
- ▶ backlash free
- ▶ low imbalance

#### DESIGN

Two precision machined coupling hubs and precision spacer mounted to the disc packs by means of high strength screws and spacers for frictional clamping of the assembly.

#### MATERIAL

- ▶ **Disc packs:** highly elastic spring steel
- ▶ **Hubs and spacer:** aluminium

S = Single flex coupling

D = Double flex coupling

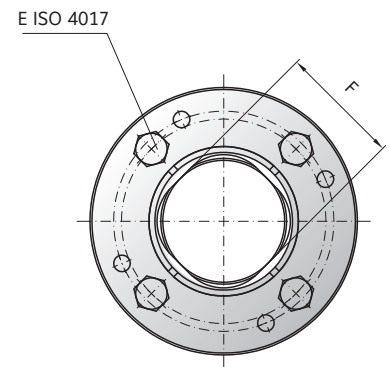
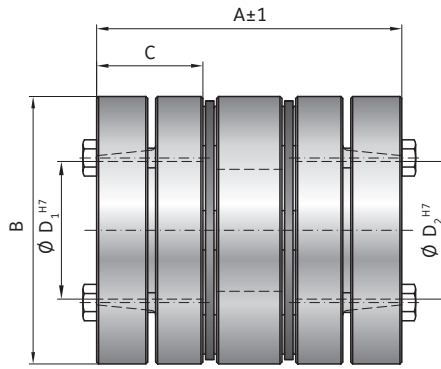
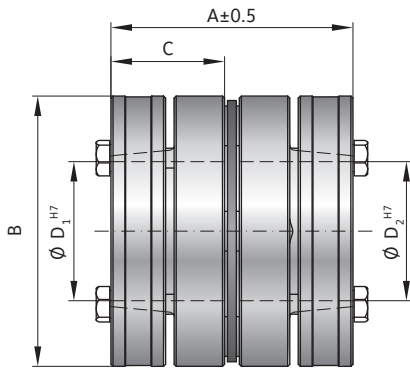

## MODEL SCL3

SIZE		25		40		60		100	
System		S	D	S	D	S	D	S	D
Rated torque (Nm)	$T_{KN}$	25		40		60		100	
Maximum torque (mm)	$T_{Kmax}$	37.5		60		90		150	
Coupling length (mm)	A	56.6	73.2	56.9	75.3	57.5	77.6	73.7	103.8
Outside diameter (mm)	B	56		63		68		82	
Fit length (mm)	C	27		27		27		32.5	
Bore diameter H7 (mm)	$D_1 / D_2$	18-28		20-30		27-35		24-40	
Fastening screw	E	M5		M5		M5		M5	
Tightening torque (Nm)		5.5		6		6		6	
Shaft diameter limitation (mm)	F	26		-		31		38	
Moment of inertia ( $10^{-3} \text{ kgm}^2$ )	$J_{ges}$	0.144	0.187	0.230	0.304	0.310	0.422	0.837	1.170
Weight (kg)		0.299	0.390	0.384	0.508	0.435	0.603	0.835	1.156
Torsional stiffness (Nm/rad)	$C_T$	46000	23000	58000	29000	82000	41000	157000	78500
Axial displacement ± (mm)		0.4	0.81	0.42	0.85	0.5	1	0.55	1.15
Lateral displacement ± (mm)	max. values	-	0.29	-	0.32	-	0.35	-	0.53
Angula displacement ± (degree)		1	2	1	2	1	2	1	2
Max. speed (1/min)		10000							

ORDERING EXAMPLE	SCL3	60	D	28	33	XX
Model	●					
Size		●				
System			●			
Bore Ø D1 H7				●		
Bore Ø D2 H7					●	

For custom features place an XX at the end of the part number and describe the special requirements (SCL3 / 60 / D / 28 / 33 / XX)

Special designation only (e.g. balanced G2.5)

SERVO DISC PACK COUPLINGS SCL