

Water & Steam Duoflow Fixed Syphon

Catalog C2003
Water & Low Pressure Steam Duoflow Fixed Syphon

BC-54065 SERIES

Special Design Features

- **Two widely spaced Carbon Bearings provides greater support to the syphon pipe and hoses.**
- **Carbon Seal placed under compression add strength and shock resistance. Joints lasts longer.**
- **External seal wear indicator allows for planned maintenance reducing expensive downtime.**
- **All metal wear parts are bronze for excellent corrosion resistance.**

Type “CS” Bronze Trim Rotary Joints are ideal for a wide range of applications using low pressure steam & water. These joints feature an iron casing, bronze sleeve and end cap, stainless steel spring and spring guides.

The high density carbon seal under compression and widely spaced bearing surfaces assure exceptionally long service life without lubrication. A key maintenance feature is the external seal wear indicator.

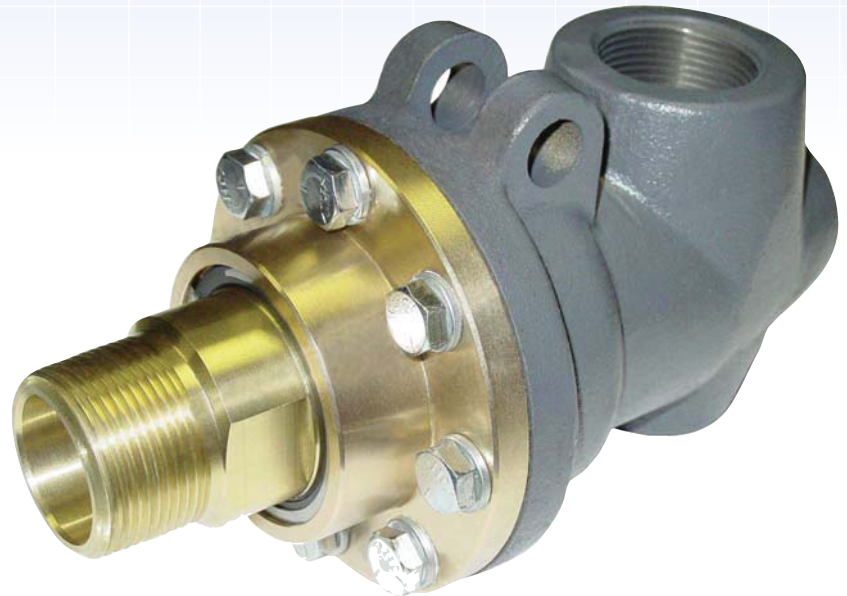

Sizes 1/2” to 3”

Operating Parameters:

Temperature:	+353°F (+178°C)
Pressure Rating:	
Steam	125 psi (8.6 BAR)
Water	300 psi (20.6 BAR)

Engineered for Performance

TYPE "C" & "CF"



Bronze Trim Construction
 Bronze sleeve and end cap, with iron casing for water, brine and low pressure steam.
 Steam - 125 psi (8.6 BAR)
 Water - 300 psi (20.6 BAR)

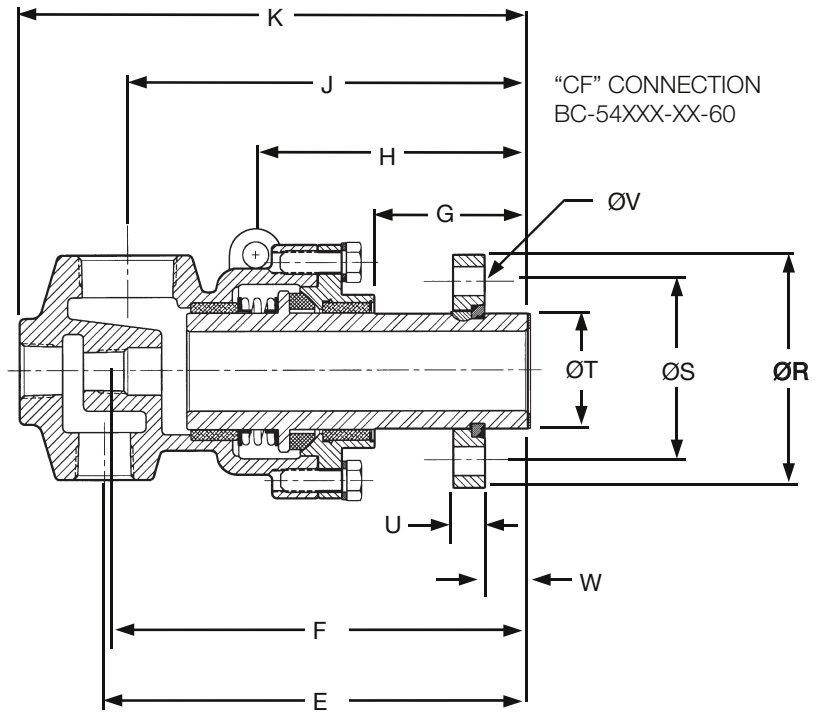

For BSPT threads:
 Add a "B" to the end of the part number.
 Example: BC-54065-08-50B

Joint Size	Bronze Trim Part Number	A NPT	B NPT	øAA	C NPT	D Syphon Thread NPT	D Syphon Thd With Bushing	E	F	G	H	J	K
1/2"	BC-54065-08-50	1/2" R.H.	1/2"	Ø.50"	1/4"	1/8"	—	5.37"	5.06"	1.73"	—	4.54"	5.87"
	BC-54065-08-51	1/2" L.H.	1/2"	Ø.50"	1/4"	1/8"	—	5.37"	5.06"	1.73"	—	4.54"	5.87"
3/4"	BC-54065-12-50	3/4" R.H.	3/4"	Ø.75"	1/2"	1/4"	1/8"	5.16"	5.25"	1.68"	—	4.54"	6.17"
	BC-54065-12-51	3/4" L.H.	3/4"	Ø.75"	1/2"	1/4"	1/8"	5.16"	5.25"	1.68"	—	4.54"	6.17"
1"	BC-54065-16-50	1" R.H.	1"	Ø1.00"	1/2"	3/8"	1/4"	5.96"	6.04"	2.03"	4.01"	5.21"	7.01"
	BC-54065-16-51	1" L.H.	1"	Ø1.00"	1/2"	3/8"	1/4"	5.96"	6.04"	2.03"	4.01"	5.21"	7.01"
	BC-54065-16-60	CF	1"	Ø1.00"	1/2"	3/8"	1/4"	6.69"	6.78"	2.77"	4.75"	5.94"	7.75"
1 1/4"	BC-54065-20-50	1 1/4" R.H.	1 1/4"	Ø1.25"	3/4"	1/2"	3/8"	6.99"	7.25"	1.89"	4.37"	6.68"	8.60"
	BC-54065-20-51	1 1/4" L.H.	1 1/4"	Ø1.25"	3/4"	1/2"	3/8"	6.99"	7.25"	1.89"	4.37"	6.68"	8.60"
1 1/2"	BC-54065-24-50	1 1/2" R.H.	1 1/2"	Ø1.50"	3/4"	3/4"	1/2"	7.48"	7.53"	2.12"	4.72"	7.04"	9.03"
	BC-54065-24-51	1 1/2" L.H.	1 1/2"	Ø1.50"	3/4"	3/4"	1/2"	7.48"	7.53"	2.12"	4.72"	7.04"	9.03"
	BC-54065-24-60	CF	1 1/2"	Ø1.50"	3/4"	3/4"	1/2"	8.89"	8.94"	3.53"	6.13"	8.45"	10.45"
2"	BC-54065-32-50	2" R.H.	2"	Ø1.88"	1 1/4"	3/4"	1/2"	8.62"	8.62"	2.19"	5.01"	8.06"	10.63"
	BC-54065-32-51	2" L.H.	2"	Ø1.88"	1 1/4"	3/4"	1/2"	8.62"	8.62"	2.19"	5.01"	8.06"	10.63"
	BC-54065-32-60	CF	2"	Ø1.88"	1 1/4"	3/4"	1/2"	10.09"	10.08"	3.66"	6.48"	9.53"	12.10"
2 1/2"	BC-54065-40-50	2 1/2" R.H.	2 1/2"	Ø2.25"	1 1/4"	1"	3/4"	10.14"	10.24"	2.91"	6.33"	9.76"	12.45"
	BC-54065-40-51	2 1/2" L.H.	2 1/2"	Ø2.25"	1 1/4"	1"	3/4"	10.14"	10.24"	2.91"	6.33"	9.76"	12.45"
	BC-54065-40-60	CF	2 1/2"	Ø2.25"	1 1/4"	1"	3/4"	10.09"	10.56"	3.66"	6.48"	9.53"	12.10"
3"	BC-54065-48-50	3" R.H.	3"	Ø2.88"	1 1/2"	1 1/2"	1"	10.86"	11.03"	3.05"	6.60"	10.67"	13.04"
	BC-54065-48-51	3" L.H.	3"	Ø2.88"	1 1/2"	1 1/2"	1"	10.86"	11.03"	3.05"	6.60"	10.67"	13.04"
	BC-54065-48-60	CF	3"	Ø2.88"	1 1/2"	1 1/2"	1"	11.35"	11.53"	3.55"	7.10"	11.16"	13.53"

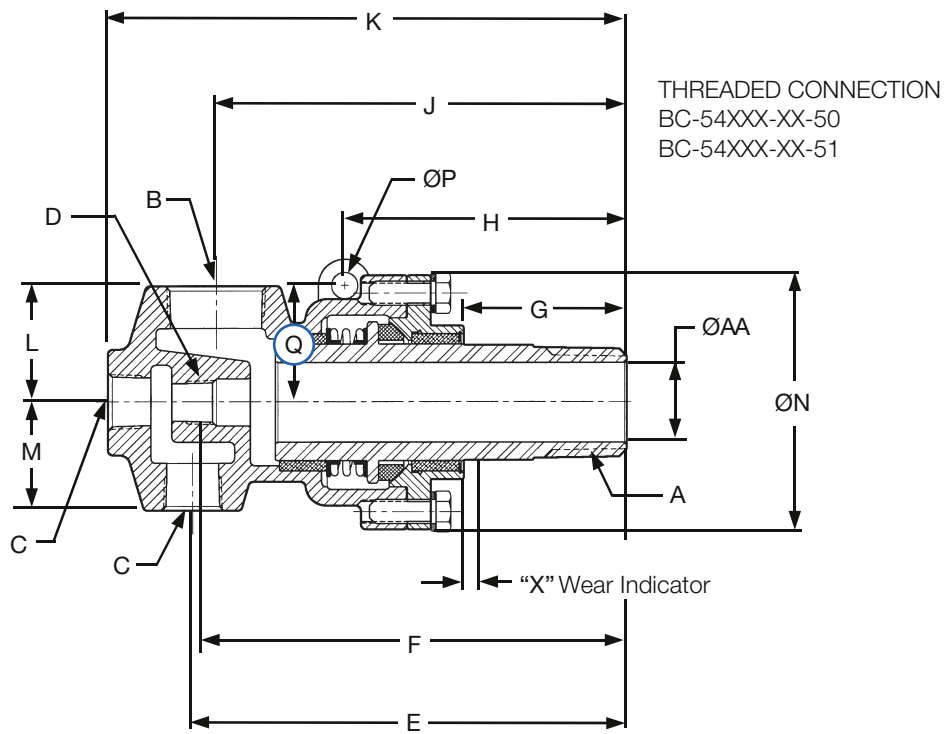

L	M	ØN	ØP	Torque Rod O.D. Max.	Q	ØR	ØS	ØT	U	4X ØV	W	"X"	Weight	Joint Size
1.62"	1.16"	Ø3.00"	—	—	—	—	—	—	—	—	—	.19"	3.5 lbs.	1/2"
1.62"	1.16"	Ø3.00"	—	—	—	—	—	—	—	—	—	.19"	3.5 lbs.	
1.75"	1.25"	Ø3.38"	—	—	—	—	—	—	—	—	—	.19"	5 lbs.	3/4"
1.75"	1.25"	Ø3.38"	—	—	—	—	—	—	—	—	—	.19"	5 lbs.	
2.06"	1.25"	Ø3.62"	Ø.50"	Ø.38"	1.75"	—	—	—	—	—	—	.25"	6 lbs.	1"
2.06"	1.25"	Ø3.62"	Ø.50"	Ø.38"	1.75"	—	—	—	—	—	—	.25"	6 lbs.	
2.06"	1.25"	Ø3.62"	Ø.50"	Ø.38"	1.75"	Ø3.88"	Ø2.75"	Ø1.399"-1.401"	.75"	Ø.56"	1.092"	.25"	9 lbs.	
2.19"	1.78"	Ø4.38"	Ø.62"	Ø.50"	2.09"	—	—	—	—	—	—	.25"	13 lbs.	1 1/4"
2.19"	1.78"	Ø4.38"	Ø.62"	Ø.50"	2.09"	—	—	—	—	—	—	.25"	13 lbs.	
2.44"	2.06"	Ø4.75"	Ø.62"	Ø.50"	2.26"	—	—	—	—	—	—	.25"	15 lbs.	1 1/2"
2.44"	2.06"	Ø4.75"	Ø.62"	Ø.50"	2.26"	—	—	—	—	—	—	.25"	15 lbs.	
2.44"	2.06"	Ø4.75"	Ø.62"	Ø.50"	2.26"	Ø4.88"	Ø3.62"	Ø2.091"-2.093"	.75"	Ø.69"	1.092"	.25"	19 lbs.	
2.75"	2.56"	Ø6.00"	Ø.62"	Ø.50"	2.76"	—	—	—	—	—	—	.31"	26 lbs.	2"
2.75"	2.56"	Ø6.00"	Ø.62"	Ø.50"	2.76"	—	—	—	—	—	—	.31"	26 lbs.	
2.75"	2.56"	Ø6.00"	Ø.62"	Ø.50"	2.76"	Ø5.50"	Ø4.25"	Ø2.714"-2.716"	.75"	Ø.69"	1.092"	.31"	31 lbs.	
3.00"	2.50"	Ø6.75"	Ø.75"	Ø.62"	3.06"	—	—	—	—	—	—	.25"	33 lbs.	2 1/2"
3.00"	2.50"	Ø6.75"	Ø.75"	Ø.62"	3.06"	—	—	—	—	—	—	.25"	33 lbs.	
3.00"	2.50"	Ø6.75"	Ø.75"	Ø.62"	3.06"	Ø5.88"	Ø4.62"	Ø3.089"-3.091"	.75"	Ø.75"	1.092"	.25"	40 lbs.	
3.62"	2.88"	Ø7.88"	Ø.94"	Ø.75"	3.62"	—	—	—	—	—	—	.25"	45 lbs.	3"
3.62"	2.88"	Ø7.88"	Ø.94"	Ø.75"	3.62"	—	—	—	—	—	—	.25"	45 lbs.	
3.62"	2.88"	Ø7.88"	Ø.94"	Ø.75"	3.62"	Ø6.50"	Ø5.25"	Ø3.714"-3.716"	.75"	Ø.69"	1.092"	.25"	50 lbs.	

CF Connection

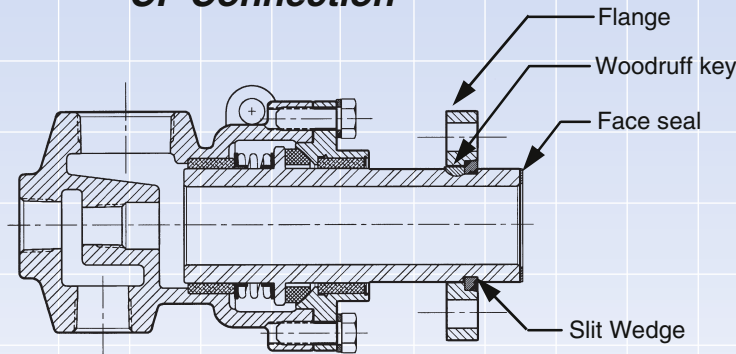

Journal Dimensions

Joint size	CF Connection	
	ØA	B
1"	Ø1.408"-1.406"	1.052"
1 1/2"	Ø2.099"-2.096"	1.052"
2"	Ø2.724"-2.721"	1.052"
2 1/2"	Ø3.099"-3.096"	1.052"
3"	Ø3.724"-3.721"	1.052"

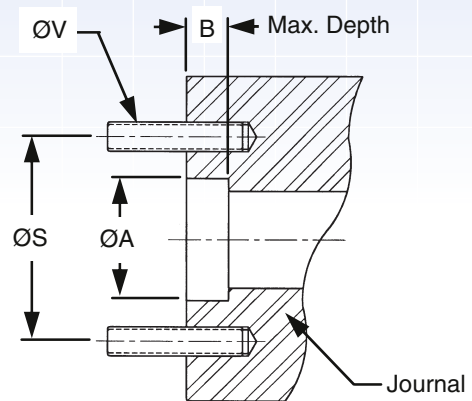

Repair Kits

Joint Size	Part Number
1/2"	10-27274-00
3/4"	10-27275-00
1"	10-27276-00
1 1/4"	10-27277-00
1 1/2"	10-27278-00
2"	10-27279-00
2 1/2"	10-27280-00
3"	10-27281-00

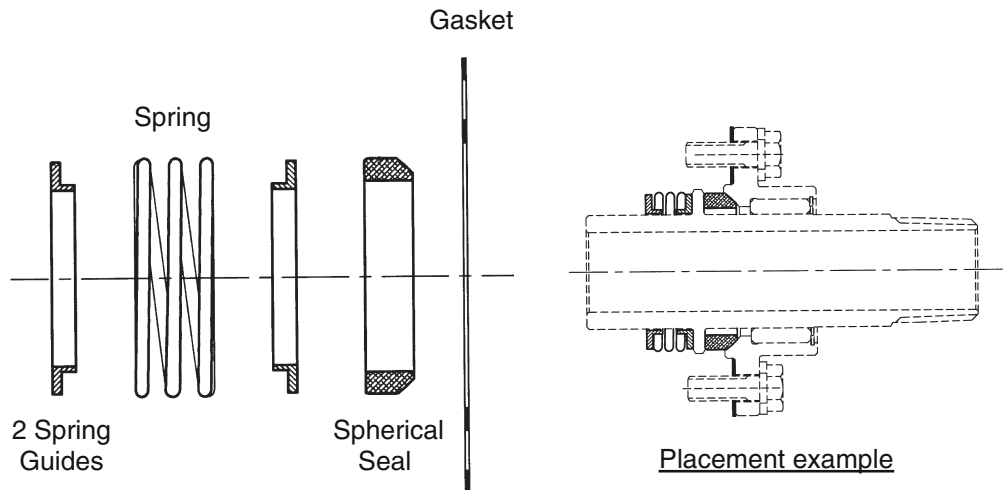

DEUBLIN GmbH
Nassaustraße 10
65719 Hofheim a. Ts.

Fon: +49 - 6122 - 8002-0

Fax: +49 - 6122 - 15 888

E-Mail: info@deublin.de